

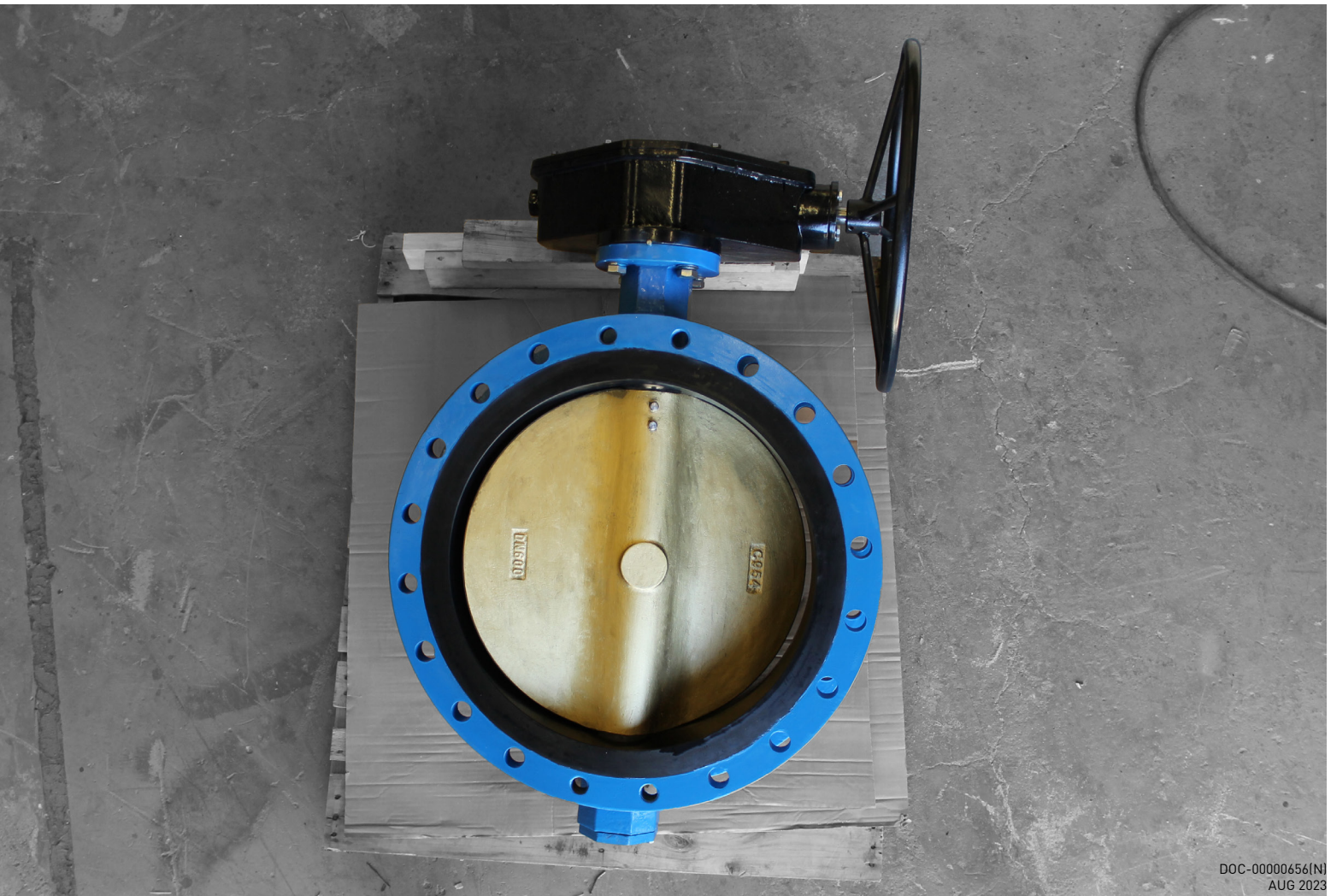

**SERIES BFI
AWWA C504
CONCENTRIC BUTTERFLY
VALVES**

3"-42"



Series BFI

Resilient Seated Butterfly
Valves to AWWA C504



NUMEROUS ACTUATION OPTIONS

Standard ISO mounting top plates offer the ability to mount numerous actuator styles directly. Shown is our standard and reliable traveling nut operator.

SIMPLE AND EFFICIENT PACKING

Designed for easy removal of packing gland while valve is still on the line for packing replacement with off the shelf packing.

LONG LIFE BEARINGS

The upper and lower bearings are standard stainless steel backed PTFE style bearings. Providing low friction and long life.

STANDARD ASTM A536 BODY

Ductile iron is the standard body material for exceptional life and strength. Numerous options for standard ANSI B16.1 Class 125 flanged, mechanical joint, and wafer available. ANSI B16.5 Class 150 options and 250B classifications are also available.

FUSION BONDED EPOXY

Valve is fully coated with a fusion-bonded epoxy conforming to AWWA C550. Suitable for buried service or field applied topcoats.

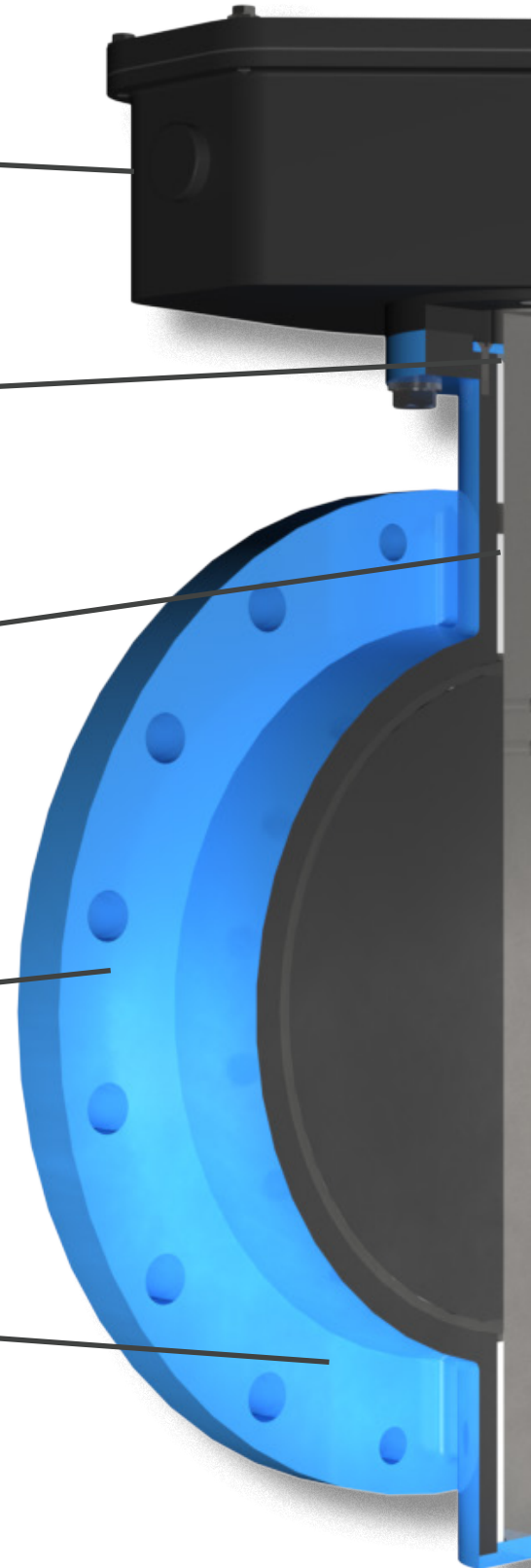

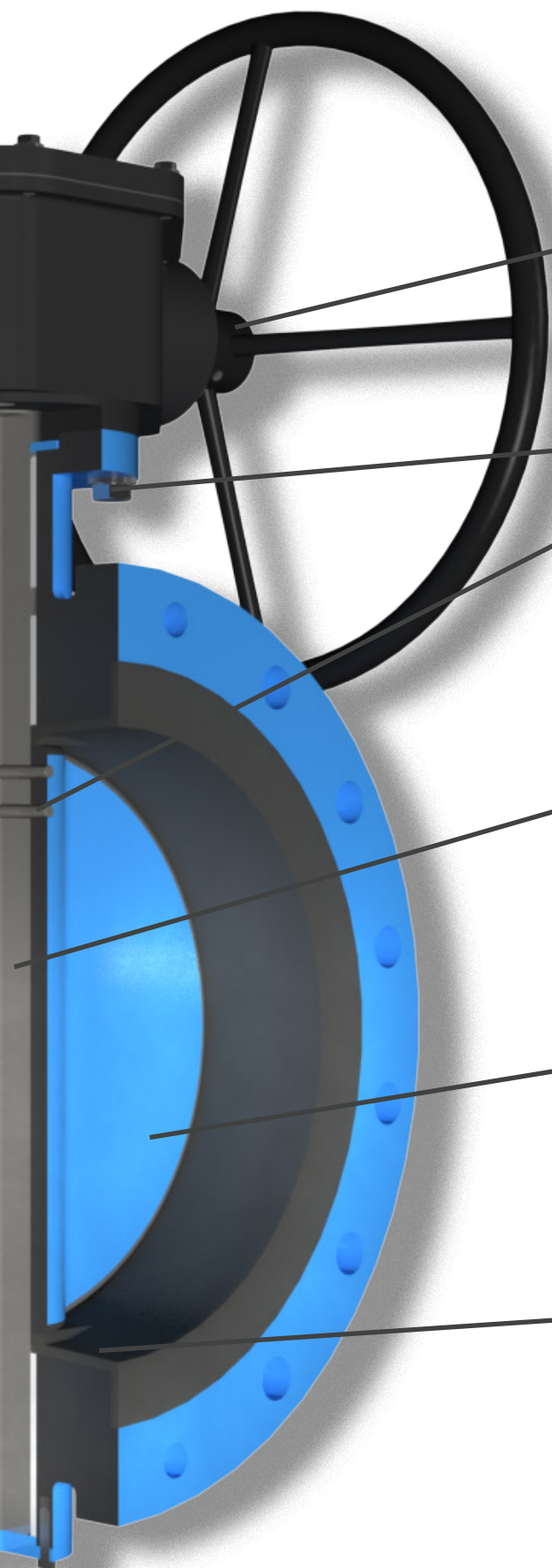

HANDWHEEL OR NUT OPTIONS

Butterfly gearbox operators available with both handwheels and 2" nut.

STAINLESS STEEL HARDWARE

Valves come standard with Stainless Steel 304 hardware for long service life in buried/submerged and harsh service conditions. Additional options available for corrosive and extreme exposures.

STAINLESS STEEL SHAFT

One piece Stainless Steel 304 shafts are standard on the Series BFI Butterfly valve. The corrosion resistant Stainless Steel features high tensile strength for a long trouble free life. Additional options available tailored to customer desires.

STREAMLINE DISC

A streamline lense-shaped disc is instituted to provide a high flow capacity with minimal head loss. All discs come standard with stainless steel 316 seat edge. Disc material comes standard as SS304 on 2"-6" and ASTM 536 ductile iron on 8"-24" valves.

BONDED SEAT

An integrally molded resilient seat is bonded to the valve body, and designed to last the life of the valve with no service. The entire body of the valve is protected from in line flow from face to face.

Series BFI

Resilient Seated Butterfly
Valves to AWWA C504



The VSI Advantage

All Series BFI Butterfly Valves come standard with the far superior Ductile Iron body and either a stainless 316 or ductile iron disc. The higher strength of Ductile Iron compared to Cast Iron allows all valves up to 24" to be rated to a full 250 psi for Class 150B valves. Additionally, by utilizing heavy duty thick wall castings to AWWA C509 and modern Ductile Iron as the material, valves comply with the requirements of AWWA C504.

Size	AWWA C504	Series BFI
2"-24"	150psi	250psi
30"-42"	150psi	150psi



As standard, all Series BFI Butterfly Valves feature a one-piece corrosion resistant shaft supported by self-lubricating PTFE bearings for an extended low friction life cycle. All sizes feature a zero slip, mechanically secured connection between the one-piece shaft and the disc. Shafts come standard in stainless steel and can be customized to meet project requirements. Shafts are stainless as standard, with many options available to meet project requirements.

Rather than allowing line-flow to contact bushings and bearings, VSI has chosen to isolate these components. The bonded seat features integral sealing ridges placed between line-flow and all friction reducing and drive supporting components. This design results in longer service life, reduced leakage possibilities, and wider range of materials. Additionally, we place packing sets in the upper and lower shaft area to eliminate the possibility of any leakage.

VSI AWWA C504 valves use a standard ISO valve stem size. This combined with industry standard stack heights allows for the use of off-the-shelf packing. The packing gland and retention design further allows for the replacement of the packing without removing the valve from the line. In some cases the line pressure can be maintained. All service can be performed without any special training.



Implementations

The Butterfly Valve has been a standard for reliable, rugged, and resistant use throughout many applications. 2"-42" VSI BFI valves can be found in water treatment and filtration systems, power plants, gas and oil, pipelines, and pumping stations across the continent. The body is fully lined with resilient material to match the line media's properties, allowing no media to body contact. Valves in this line are designed to meet and exceed AWWA C504 standards.

Bonded Seat

VSI butterfly valves from 3 to 42 inches are offered with an integrally molded resilient seat bonded to the valve body. The seat is designed to last the life of the valve with no servicing needed while still providing drip-tight shut-off of line flow. The entire body of the valve is protected from line flow from face to face. The seat design has completed AWWA proof of design testing and is bond tested per ASTM D429 for peel strength. This proven and tested design provides a trouble-free extended life.

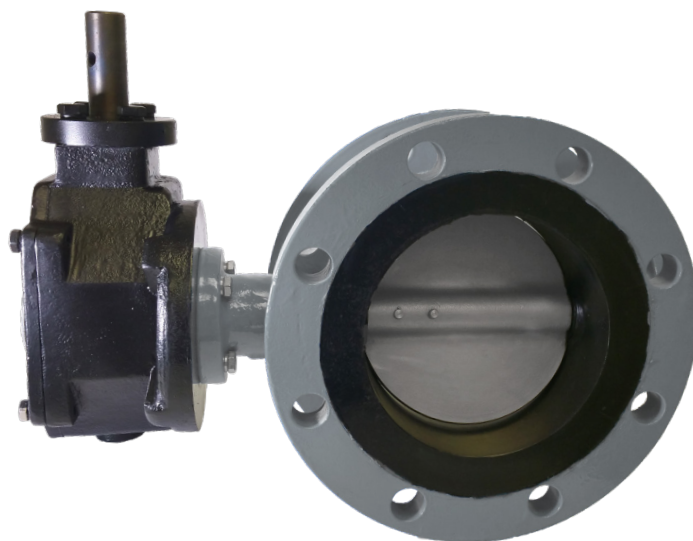

PAGE 5



Streamlined Disc

A streamlined lens-shaped disc is instituted to provide a high flow capacity with minimal head loss. Extensive analysis and testing has been undertaken to assure that significant improvements in the valve coefficient could be achieved. With the streamlined disc attached to our standard stainless steel shaft, you can expect for rigid and reliable valve function.

Series BFI

Resilient Seated Butterfly
Valves to AWWA C504



ANSI/NSF 61 Listed

VSI's Series BFI standard build butterfly valves are ANSI/NSF 61 Listed for drinking water along with ANSI/NSF-372 certified lead-free.



WATER QUALITY

Available as:

Underwriters Lab Inc. listed
ANSI/NSF 61
Also classified
ANSI/NSF 372
<MH60347>

VSI's BFI valves are painted in Resicoat® R4-ES Product Code HJ-F14R, which is a thermosetting epoxy powder designed as a coating for water and gas pipeline service. This product has been certified to meet the requirements of ANSI/NSF 61 for Potable Water system components.



Sample Specification

3-24 Inch Butterfly Valve, Bonded Body Seal Valves for Waterworks Service

1. SCOPE
 - 1.1. This specification covers the design, manufacture, and testing of cast butterfly valves 3 inch (75 mm) to 42 inch (1050mm) under service pressure of up to 250 psig (1725 kPa).
 - 1.2. Butterfly valves shall be resilient seated and of the quarter turn, concentric, bonded seal in body type.
2. GOVERNING STANDARDS
 - 2.1. All butterfly valves shall be in full conformance with the design, manufacturing, and testing standards set forth by the American Water Works Association (AWWA) in Standard ANSI/AWWA C504.
 - 2.2. When requested, manufacturer shall provide an Affidavit of Proof of Design Testing in accordance with AWWA C504.
3. CONNECTIONS
 - 3.1. Flanged valves shall conform to all standards of ANSI B16.1, Class 125 or Class 250.
 - 3.2. Flanged valves' lay length shall conform to AWWA C504 Table 1, Short Body.
 - 3.3. Mechanical joint valves shall conform to all standards of ANSI/AWWA C111/A21.11.
4. MARKINGS
 - 4.1. Each valve shall be marked with the manufacturer's name, valve size, body material, and pressure rating cast into the body of the valve. Lettering shall be a minimum of 1/2 inch tall and project 1/10 inch from body.
 - 4.2. All butterfly valves, except buried or submerged valves, shall be equipped with a type 304 or 316 stainless steel tag identifying body, disc, resilient seat, and stem material in addition to manufacturer's name, pressure rating, size, date of manufacturer, and date of testing.
5. DESIGN
 - 5.1. Valves shall be equipped with either a seat directly bonded to a machined finished surface on valve disc or an entirely corrosion resistant disc with machined seat. Plated or removable seats are not acceptable.
 - 5.2. Valve shall have a permanently installed seal bonded to the body of the valve. The seal-to-body bond shall comply with ASTM D429 pull test.
 - 5.3. Valve shall be equipped with a set of V-type stem packing. Valve stem packing shall be replaceable without removing the valve from the line and be adjustable by means of shims.
 - 5.4. Radial shaft bushings shall be supplied in the upper and lower bearing journals.
 - 5.5. The valves shall be equipped with a mounting area for operators conforming to Manufacturers Standard Society (MMS) 101 or International Organization of Standardization (ISO) 5211. There shall be sufficient clearance to directly mount standardized operators with easily accessible fasteners.
 - 5.6. Stem diameter shall be the preferred dimension stated in ISO 5211 Table 4.
 - 5.7. Drive keys shall comply with ISO R773, unless specifically stated otherwise. Preferred tolerance is D10. Tolerance of Js9 is acceptable for motor operated valves.
 - 5.8. Valves shall provide a bubble-tight shutoff bi-directionally at rated working pressure.
6. MATERIALS
 - 6.1. The valve body and bonnet if equipped shall be constructed of ASTM A536 Ductile Iron.
 - 6.2. The valve disc shall be either ASTM A536 Ductile Iron or ASTM A351 Stainless Steel
 - 6.3. For valves with iron discs the seat shall be applied to the disc in the form of a minimum of 95% nickel, type 316 stainless steel, or stellite. For valves with Stainless Steel discs the seat shall be machined into the disc edge.
 - 6.4. The valve seal shall be made from resilient NBR, EPDM, or FPM as specified.
 - 6.5. Radial bearings shall be made of permanently lubricated RTFE or lead free Bronze.
 - 6.6. All submerged coatings shall conform to AWWA C550, be holiday free, and have a minimum total dry film thickness of 10 mils.
 - 6.7. All wetted hardware should be of corrosion resistant type 304 or 316 stainless steel as specified.
 - 6.8. All uncovered, submerged, or buried valves shall have type 304 or 316 stainless steel exterior hardware. All others shall have zinc plated carbon steel hardware unless specified.
7. OPERATORS
 - 7.1. All manually operated valves 8 inches and larger shall be equipped with a gear actuator with position indicator. Operator should be designed to hold the valve in any intermediate position without creeping or fluttering.
 - 7.2. All actuators shall be permanently sealed and suitable for buried service.
 - 7.3. All 2 inch square operating nuts and exposed hardware shall be made of stainless steel.
 - 7.4. All actuators equipped with handwheels shall have a maximum rim pull of 80 lbs plus 5%.
8. MANUFACTURER
 - 8.1. Concentric butterfly valves shall be VSI Series BFI as manufactured by Valve Solutions, Inc., Alpharetta, GA USA.
 - 8.2. All valves shall be warranted by manufacturer for a minimum of 12 months.



Materials of Construction

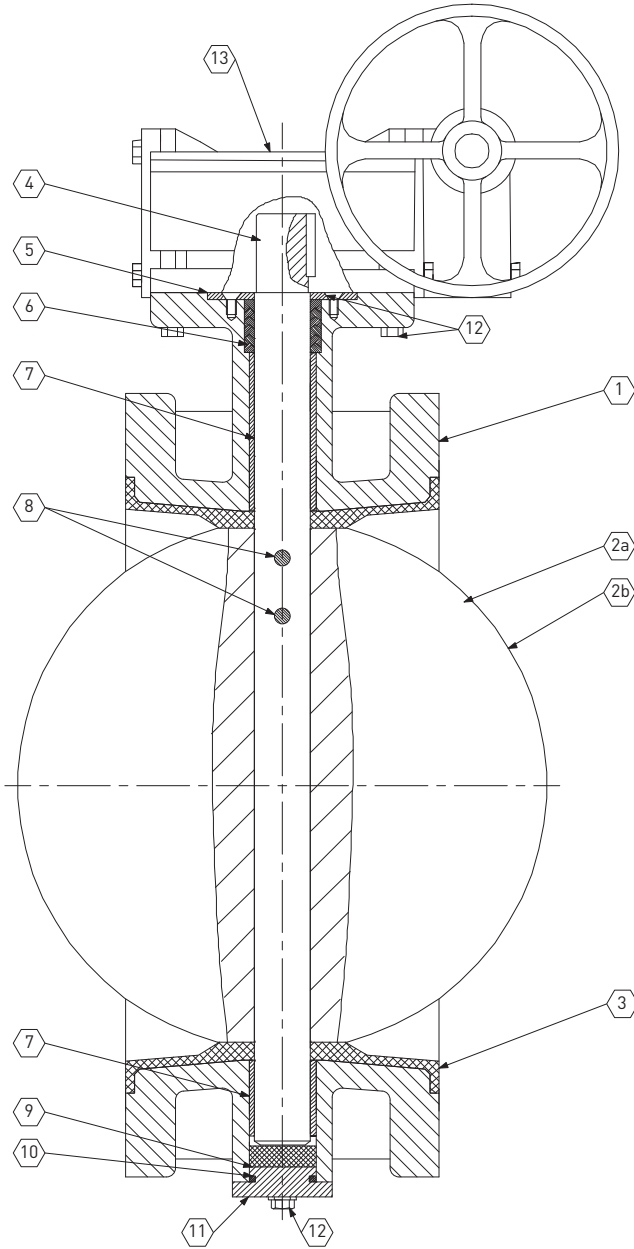

PAGE 8

Additional material options available as special order.

- (1) Standard on sizes 8" and larger
- (2) Standard on sizes 6" and smaller
- (3) Standard on Stainless Steel or Bronze disc
- (4) Standard on Iron discs
- (5) Required for AWWA Class 250B valves

Item	Description	Materials Available	Standard
1	Body	Ductile Iron*	ASTM A536 65-45-12
		Cast Iron	ASTM A126 Class B
		Stainless Steel 304	ASTM A351 CF8
		Stainless Steel 316	ASTM A351 CF8M
2a	Disc	Ductile Iron* ⁽¹⁾	ASTM A536 65-45-12
		Cast Iron	ASTM A126 Class B
		Stainless Steel 304	ASTM A351 CF8
		Stainless Steel 316* ⁽²⁾	ASTM A351 CF8M
		Aluminum Bronze	ASTM B148 C954
2b	Disc Edge	Machined Surface* ⁽³⁾	
		Stainless Steel 316 Welded Overlay* ⁽⁴⁾	
		95% Nickel Welded Overlay	
3	Seat	EDPM*	
		Buna-N (NBR)	
4	Shaft	Viton (FPM)	
		Stainless Steel 304*	ASTM A276
		Stainless Steel 316	ASTM A276
5	Retainer	Stainless Steel 17-4PH ⁽⁵⁾	ASTM A564
		Steel*	ASTM A36
6	Packing	Stainless Steel 304	ASTM A276
7	Bearing	Same as Seat	
		Reinforced PTFE*	
8	Pin/s	Bronze	ASTM B584
		Stainless Steel 304*	ASTM A276
		Stainless Steel 316	ASTM A276
9	Ring	Stainless Steel 17-4PH ⁽⁵⁾	ASTM A564
		Nylon*	
10	Seal	Reinforced PTFE	
		Bronze	ASTM B584
11	Cap	Same as Seat	
		Ductile Iron*	ASTM A536 65-45-12
12	Exterior Hardware	Stainless Steel 304	ASTM A351 CF8
		Stainless 304*	ASTM F593/594
		Stainless 316	ASTM F593/594
		Plated Steel	ASTM A325 Type 1
13	Operator	Bronze	C651
		Varies	
NS	Coating/Lining	Fusion Bonded Epoxy, Blue*	
		Two-Part Epoxy	
NS	Tag	Aluminum*	
		Stainless Steel	
NS	Assembly Lubricant	ANSI/NSF 61 Listed Silicone Lubricant	



Design Standards

Size Range	2"-42" Flanged End 2"-24" MJ End
Construction	AWWA C504 ASME B16.34 API 609
Coatings	AWWA C550* ANSI/NSF 61 Compliant
Connections	ANSI B16.1 Class 125/ANSI B16.5 Class 150* ANSI B16.1 Class 250/ANSI B16.5 Class 300 ANSI/AWWA C111/A21.11 (MJ)* ISO 7005
Lay Length	AWWA C504 Short* ISO 5752
Bonnet	MSS SP-101* ISO 5211
AWWA Classifications	150B* 250B

*Standard Option

Available as:
Underwriters Lab Inc. listed
ANSI/NSF 61
Also classified
ANSI/NSF 372
<MH60347>



WATER QUALITY



American Water Works Association

PAGE 9

Resistance Guide

Designation	Common Names	Composition	Min/Max Temperature Range	General Properties	Resistant to:	Attacked by:
EPDM	EPDM, EPM	Ethylene-propylene-diene Monomer	-40F/250F	Excellent ozone, chemical, and aging resistance. Poor resistance to petroleum-based fluids	Animal and vegetable oils, ozone, strong and oxidizing chemicals.	Mineral oils and solvents, aromatic hydrocarbons
NBR	NBR, Buna-N	Nitrile-butadiene	-30F/225F	Excellent resistance to petroleum-based fluids. Good physical properties	Many hydrocarbons, fats, oils, greases, hydraulic fluids, chemicals	Ozone, ketones, esters, aldehydes, chlorinated and nitro hydrocarbons
FPM	FPM, Viton®	Hexafluoropropylene-vinylidene fluoride	-10F/400F	Excellent oil and air resistances both at low and high temperatures. Very good chemical resistance	All aliphatic, aromatic, and halogenated hydrocarbons, acids, animal and vegetable oils	Ketones, low molecular weight esters and nitro containing compounds
PTFE	PTFE, Teflon®	Polytetrafluoro-ethylene	-100F/450F	Excellent abrasion resistance and chemically inert	Acids, harsh inorganic and organic chemicals, oils, oxidizing agents, and solvents	Molten alkali metals and fluorine at high temperatures



Pressure/Temperature Ratings

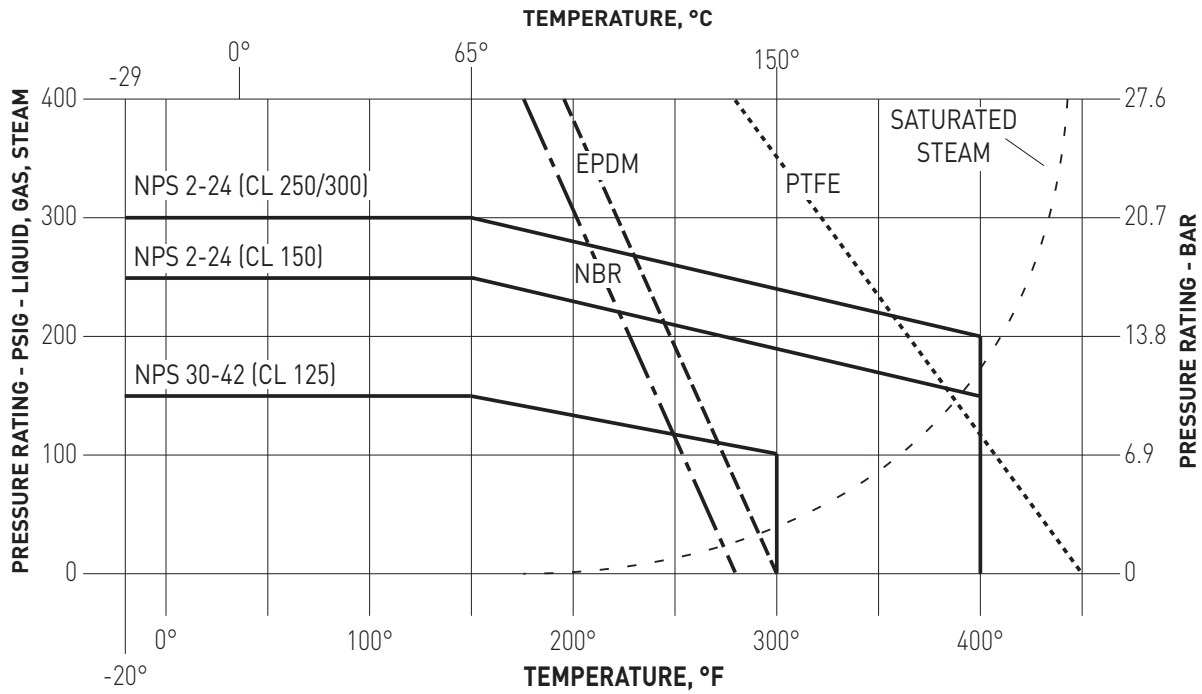

In determining field pressure ratings for Series BFI Butterfly Valves that are constructed of Ductile Iron the above chart should be used. Pressure cast on valve represents maximum seating pressure; maximum hydrostatic pressure is temperature dependent, and may be higher than nominal pressure rating.



2"-30" Flanged Barestem

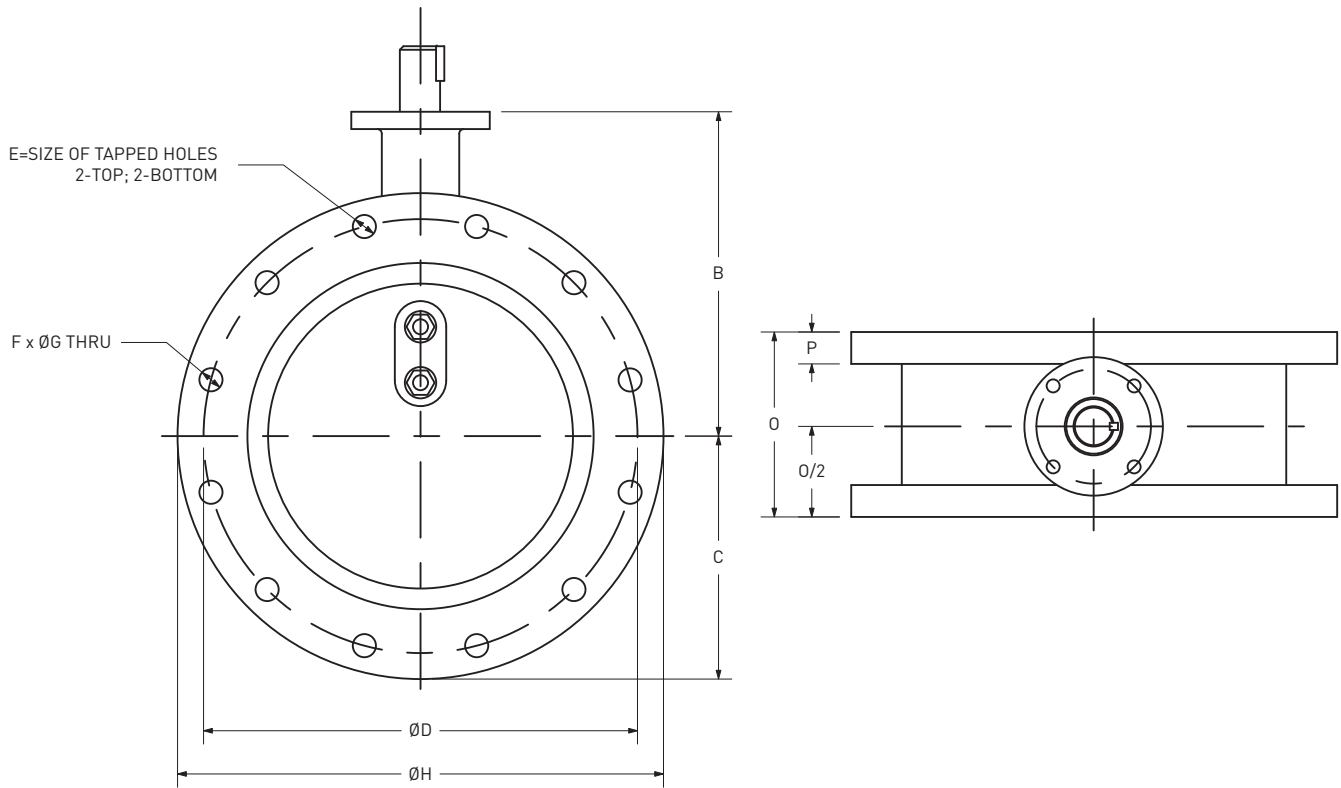

SIZE	B	C	D	E	F	G	H	O	P	ISO Mount	Weight (Lb.)
2"	4.21	3.0	4.76	-	4	0.75	5.9	5	0.75	F07	-
3"	5.16	3.8	6.0	-	4	0.75	7.5	5	0.75	F07	27
4"	5.91	4.7	7.5	-	8	0.75	9.0	5	0.94	F07	35
6"	7.09	6.1	9.5	-	8	0.88	11.0	5	1.00	F07	47
8"	8.27	7.4	11.75	-	8	0.88	13.5	6	1.13	F10	85
10"	10.12	8.2	14.25	-	12	1.0	16.0	8	1.19	F10	130
12"	10.83	9.9	17.00	-	12	1.0	19.0	8	1.25	F12	193
14"	12.91	11.4	18.75	-	12	1.12	21.0	8	1.38	F12	251
16"	14.8	12.6	21.25	1-8UNC	12	1.12	23.5	8	1.46	F14	287
18"	16.01	13.5	22.75	1.125-7UNC	12	1.26	25.0	8	1.57	F14	366
20"	17.64	16.1	25.00	1.125-7UNC	16	1.26	27.5	8	1.69	F16	429
24"	20.39	18.8	29.50	1.25-7UNC	16	1.38	32.0	8	1.88	F16	654
30"	22.05	19.4	36.00	1.25-7UNC	24	1.38	38.8	12	2.87	F25	1310



2"-24" Flanged Traveling Nut With Handwheel

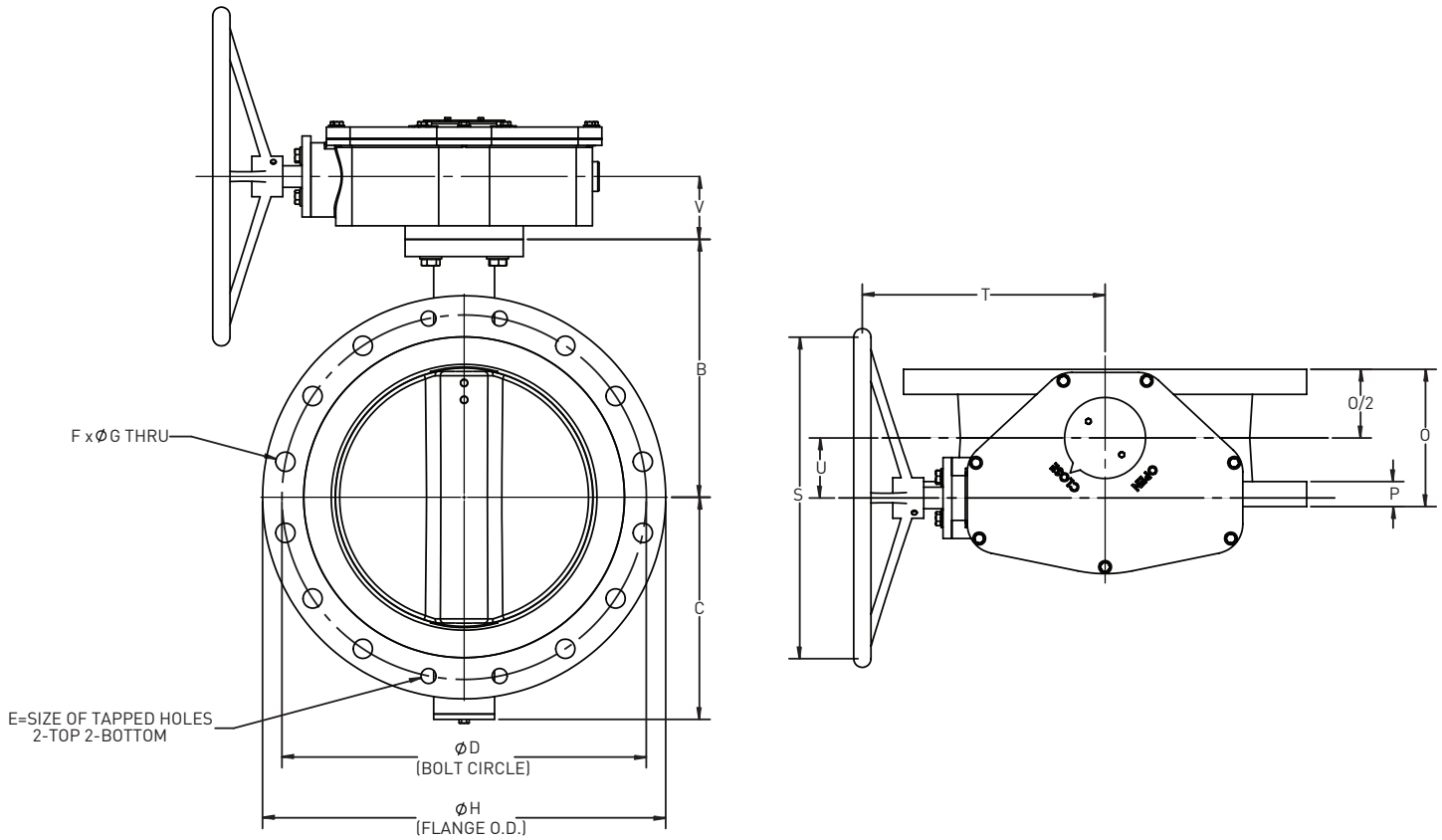

PAGE 12

SIZE	B	C	D	E	F	G	H	O	P	S	T	U	V	Weight (Lb.)
2"	4.21	3.0	4.76	-	4	0.75	5.91	5	0.75	-	-	-	-	-
3"	5.16	3.8	6.00	-	4	0.75	7.52	5	0.75	15.00	8.4	1.5	3.15	55
4"	5.91	4.7	7.50	-	8	0.75	9.02	5	0.94	15.00	8.4	1.5	3.15	63
6"	7.09	6.1	9.50	-	8	0.88	11.02	5	1.00	15.00	8.4	1.5	3.15	75
8"	8.27	7.4	11.75	-	8	0.88	13.50	6	1.13	15.00	8.4	1.5	2.40	115
10"	10.12	8.2	14.25	-	12	1.00	15.98	8	1.19	15.00	8.4	1.5	2.40	160
12"	10.83	9.9	17.00	-	12	1.00	19.02	8	1.25	15.00	9.1	1.97	2.52	237
14"	12.91	11.4	18.75	-	12	1.12	20.98	8	1.38	15.00	9.1	1.97	2.52	295
16"	14.80	12.6	21.25	1-8UNC	12	1.12	23.50	8	1.46	16.75	13.9	3.50	3.74	402
18"	16.01	13.5	22.75	1.125-7UNC	12	1.26	25.00	8	1.57	16.75	13.9	3.50	3.74	486
20"	17.64	16.1	25.00	1.125-7UNC	16	1.26	27.52	8	1.69	18.00	15.8	5.00	4.02	595
24"	20.39	18.8	29.50	1.25-7UNC	16	1.38	32.01	8	1.88	18.00	15.8	5.00	4.02	820



2"-24" Flanged Traveling Nut With 2" Nut

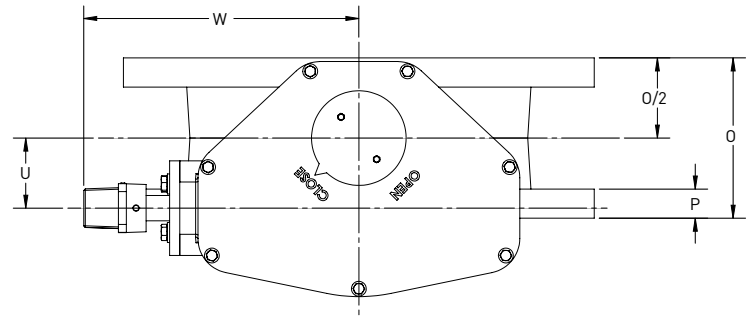
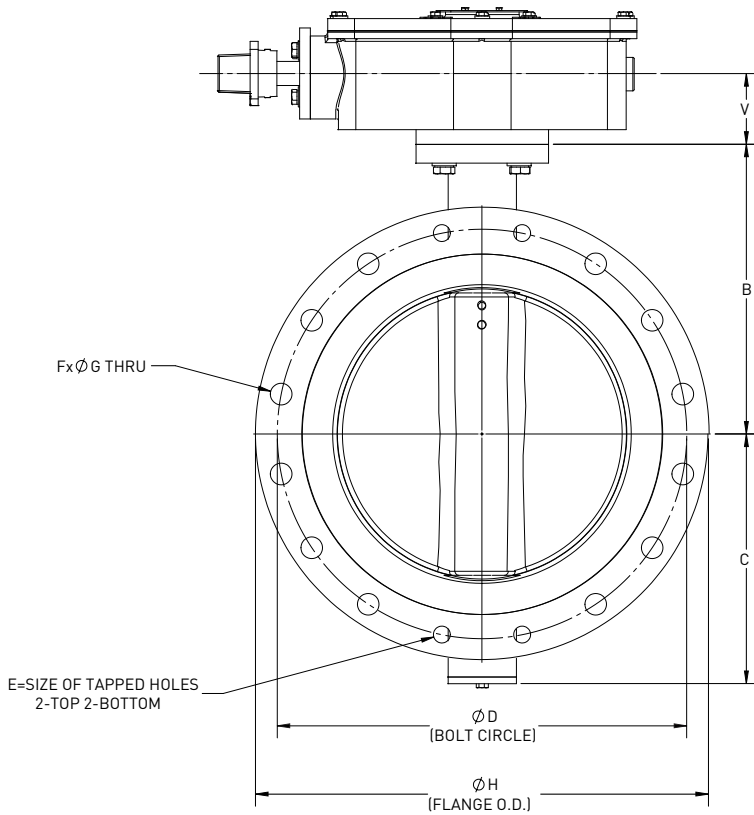

PAGE 13

SIZE	B	C	D	E	F	G	H	O	P	U	W	Weight (Lb.)
2"	4.21	3.0	4.76	-	4	0.75	5.91	5	0.75	-	-	-
3"	5.16	3.8	6.00	-	4	0.75	7.52	5	0.75	1.5	8.4	51
4"	5.91	4.7	7.50	-	8	0.75	9.02	5	0.94	1.5	8.4	59
6"	7.09	6.1	9.50	-	8	0.88	11.02	5	1.00	1.5	8.4	71
8"	8.27	7.4	11.75	-	8	0.88	13.50	6	1.13	1.5	9.4	109
10"	10.12	8.2	14.25	-	12	1.00	15.98	8	1.19	1.5	9.4	154
12"	10.83	9.9	17.00	-	12	1.00	19.02	8	1.25	1.97	9.4	231
14"	12.91	11.4	18.75	-	12	1.12	20.98	8	1.38	1.97	9.4	289
16"	14.80	12.6	21.25	1-8UNC	12	1.12	23.50	8	1.46	3.50	12.5	396
18"	16.01	13.5	22.75	1.125-7UNC	12	1.26	25.00	8	1.57	3.50	12.5	475
20"	17.64	16.1	25.00	1.125-7UNC	16	1.26	27.52	8	1.69	5.00	15.1	584
24"	20.39	18.8	29.50	1.25-7UNC	16	1.38	32.01	8	1.88	5.00	15.1	809



2"-24" Flanged Traveling Nut Gearbox with Chainwheel

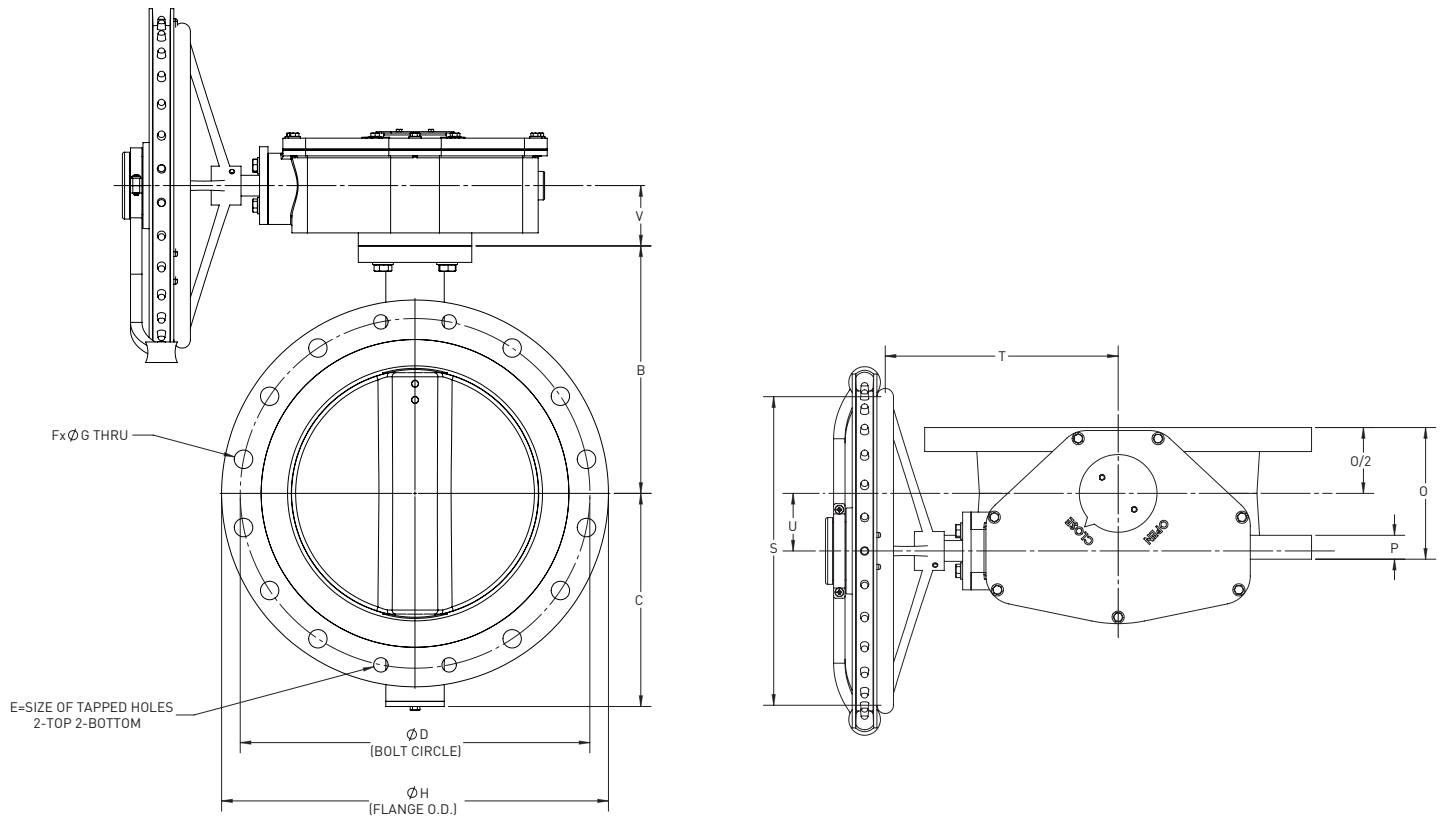

PAGE 14

SIZE	B	C	D	E	F	G	H	O	P	S	T	U	V	Weight (Lb.)
2"	4.21	3.0	4.76	-	4	0.75	5.91	5	0.75	-	-	-	-	-
3"	5.16	3.8	6.00	-	4	0.75	7.52	5	0.75	15.00	8.4	1.5	3.15	70
4"	5.91	4.7	7.50	-	8	0.75	9.02	5	0.94	15.00	8.4	1.5	3.15	78
6"	7.09	6.1	9.50	-	8	0.88	11.02	5	1.00	15.00	8.4	1.5	3.15	90
8"	8.27	7.4	11.75	-	8	0.88	13.50	6	1.13	15.00	8.4	1.5	2.40	130
10"	10.12	8.2	14.25	-	12	1.00	15.98	8	1.19	15.00	8.4	1.5	2.40	175
12"	10.83	9.9	17.00	-	12	1.00	19.02	8	1.25	15.00	9.1	1.97	2.52	252
14"	12.91	11.4	18.75	-	12	1.12	20.98	8	1.38	15.00	9.1	1.97	2.52	310
16"	14.80	12.6	21.25	1-8UNC	12	1.12	23.50	8	1.46	16.75	13.9	3.50	3.74	417
18"	16.01	13.5	22.75	1.125-7UNC	12	1.26	25.00	8	1.57	16.75	13.9	3.50	3.74	504
20"	17.64	16.1	25.00	1.125-7UNC	16	1.26	27.52	8	1.69	18.00	15.8	5.00	4.02	613
24"	20.39	18.8	29.50	1.25-7UNC	16	1.38	32.01	8	1.88	18.00	15.8	5.00	4.02	838



2"-8" Flanged With Lever

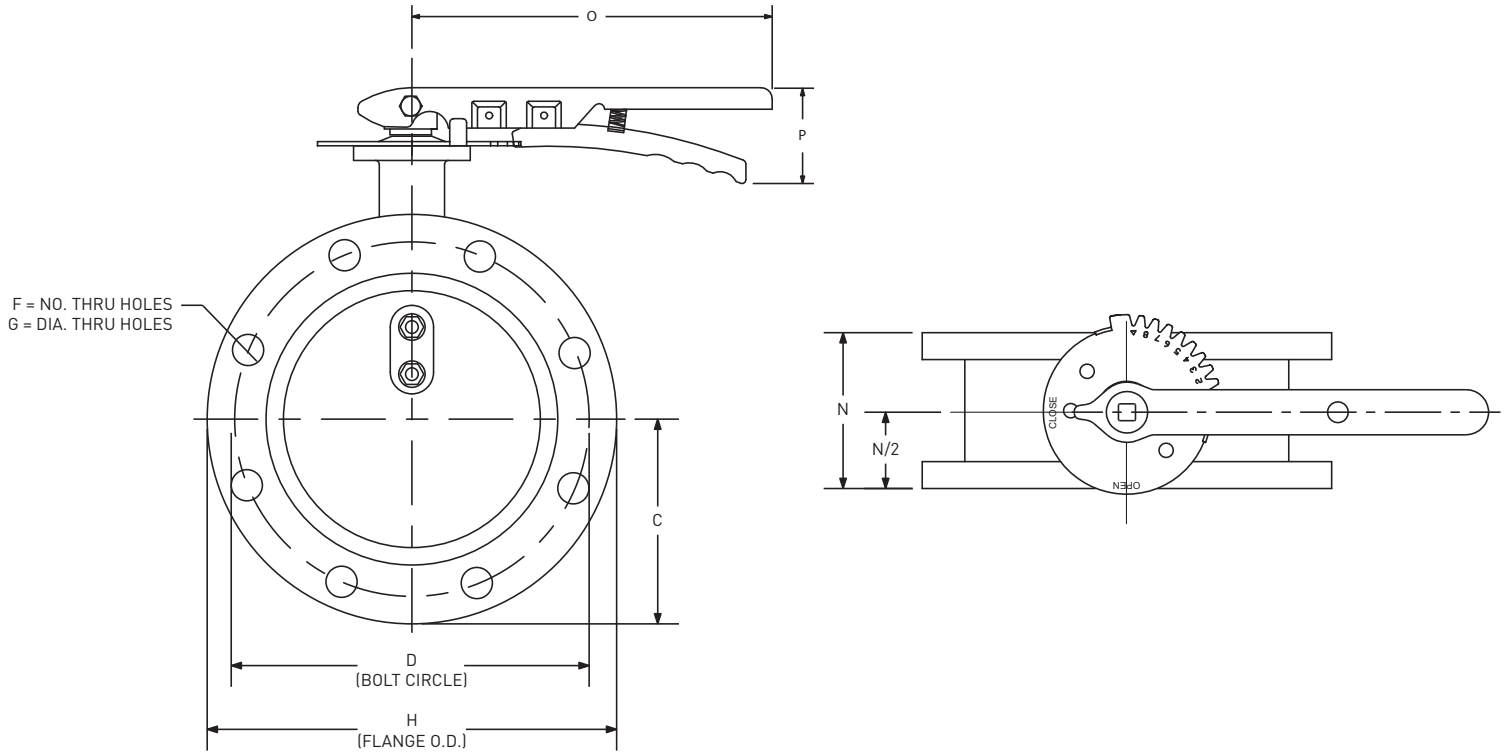

SIZE	C	D	F	G	H	N	O	P	Weight (Lb.)
2"	3.0	4.76	4	0.75	5.91	5.0	10.2	2.1	-
3"	3.8	6.0	4	0.75	7.52	5.0	10.2	2.1	30
4"	4.7	7.5	8	0.75	9.02	5.0	10.2	2.1	38
6"	6.1	9.5	8	0.88	11.02	5.0	12.3	2.6	50
8"	7.4	11.75	8	0.88	13.5	5.0	12.3	2.6	88



3"-24" Mechanical Joint with Traveling Nut Gearbox

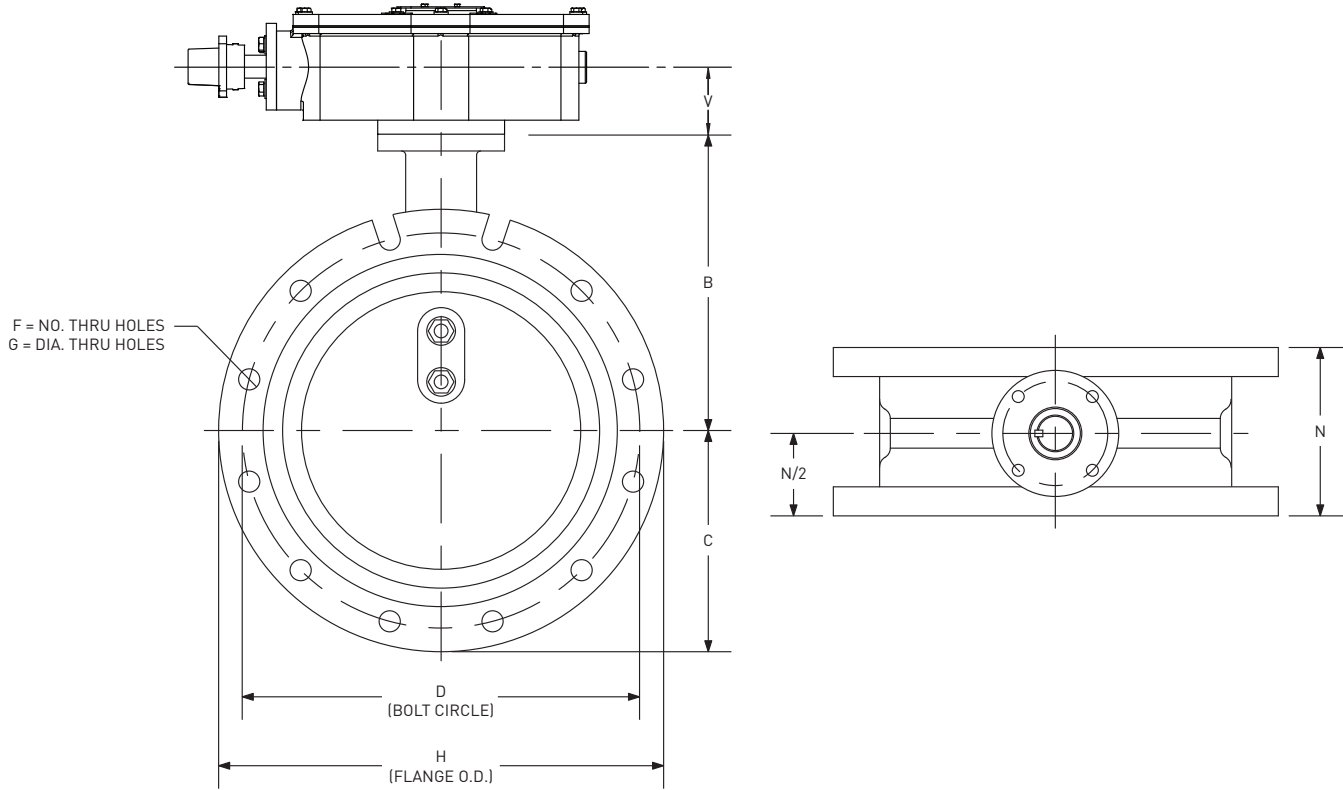

PAGE 16

SIZE	B	C	D	F	G	H	N	V	ISO Mount	Weight (Lb.)
4"	7.01	3.98	7.50	4	0.88	9.12	8.50	3.15	F07	46
6"	7.99	5.87	9.50	6	0.88	11.12	8.50	3.15	F07	82
8"	9.53	6.26	11.75	6	0.88	13.37	8.62	2.40	F10	105
10"	10.79	7.68	14.00	8	0.88	15.62	9.25	2.40	F10	151
12"	12.32	9.09	16.25	8	0.88	17.88	9.25	2.52	F12	195
14"	14.02	10.28	18.75	10	0.88	20.25	11.50	2.52	F12	254
16"	15.04	11.34	21.00	12	0.88	22.50	12.00	3.74	F14	312
18"	16.54	12.99	23.25	12	0.88	24.75	12.25	3.74	F14	433
20"	18.07	14.25	25.50	14	0.88	27.00	12.50	4.02	F16	600
24"	22.52	16.57	30.00	16	0.88	31.50	13.25	4.02	F16	833



Operating Torque and Cv Values

Torque Chart		
Size		Torque (in-lbs)
DN	IN	150psi
80	3"	284
100	4"	496
150	6"	2111
200	8"	3016
250	10"	4093
300	12"	6703
350	14"	10647
400	16"	15098
450	18"	22701
500	20"	31064
600	24"	53765
750	30"	94784
900	36"	166269
1050	42"	225411
1200	48"	353447
1350	54"	611315
1500	60"	757671
1650	66"	924936
1800	72"	1224620

Cv Valve (100% Open)			
Size		C _v	K _v
DN	IN		
80	3"	228	195
100	4"	463	396
150	6"	1069	914
200	8"	2372	2027
250	10"	4380	3744
300	12"	6515	5568
350	14"	9574	8183
400	16"	13356	11415
450	18"	16898	14443
500	20"	21421	18309
600	24"	27889	23837
750	30"	39450	33720
900	36"	59520	50870
1050	42"	85740	73280
1200	48"	112000	95800
1350	54"	141700	121000
1500	60"	172800	147700
1650	66"	209100	178700
1800	72"	2248900	212700

*Safety Factor included

BFI Flow Values (C_v)

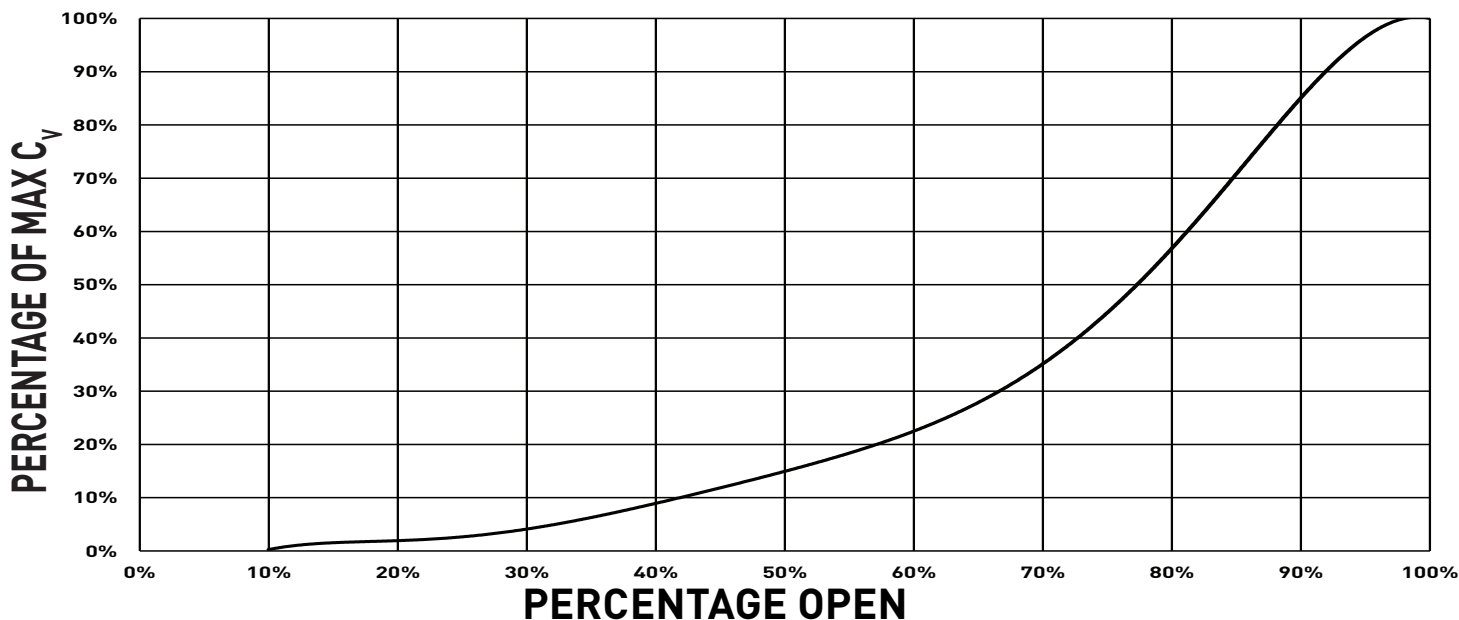



PART NUMBER MATRIX

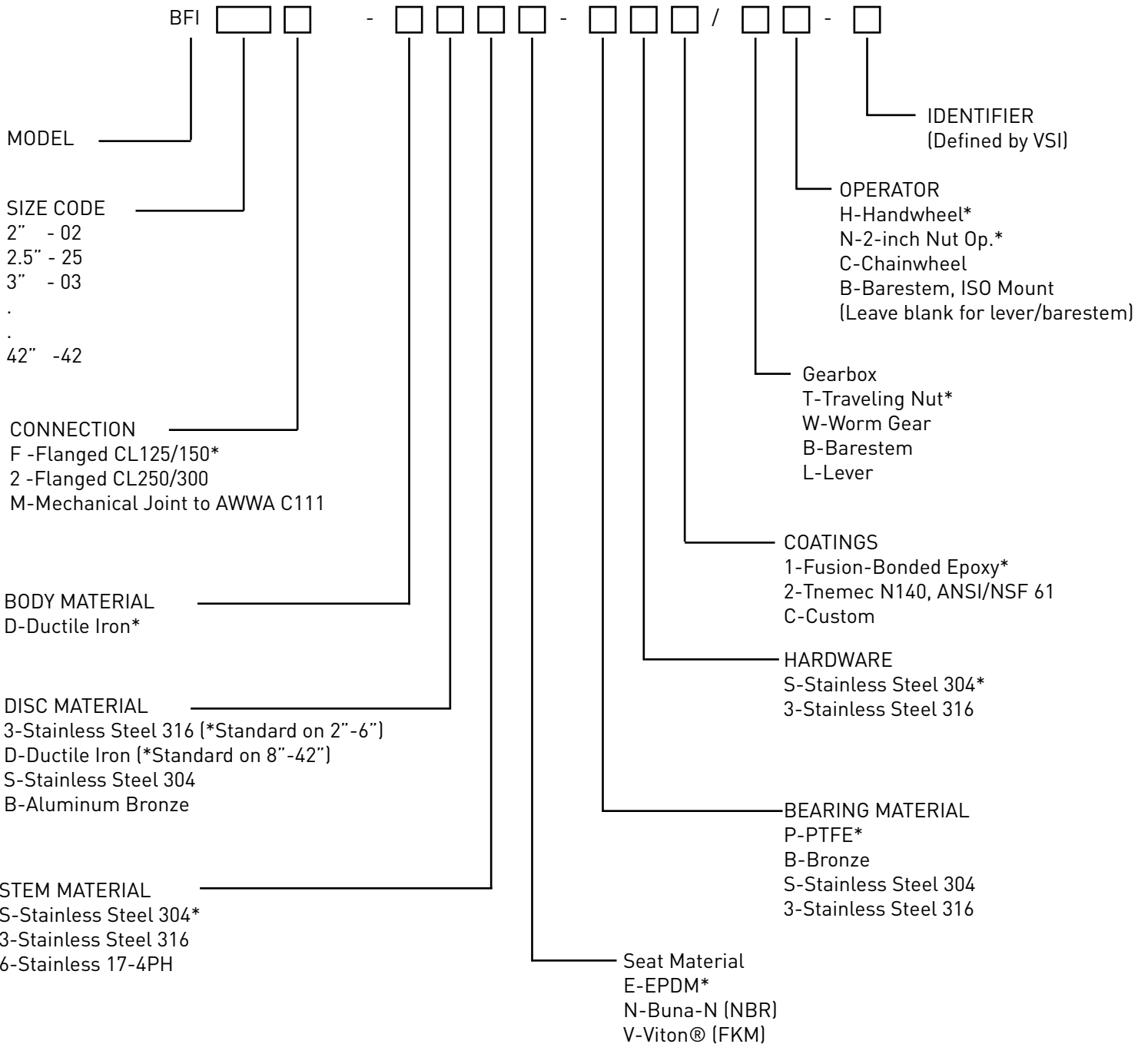

PAGE 18

* Standard Material

EXAMPLE:

BFI06F-DDSE-PS1/TH-H

A 6" flanged butterfly valve with Ductile Iron body and disc, SS304 shaft, EPDM seat, PTFE bearings material, SS304 hardware, fusion-bonded epoxy coatings with traveling nut gearbox, and handwheel operator

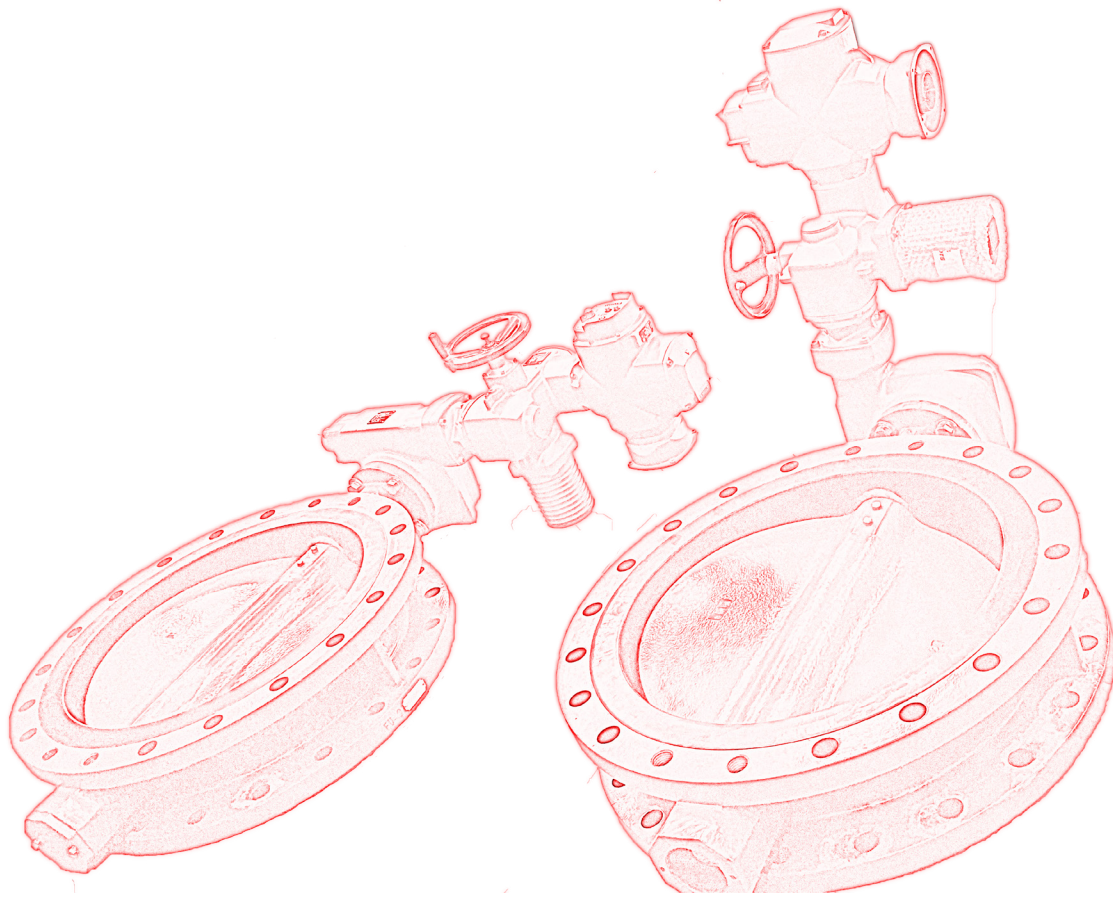

VSI Waterworks LLC

tel: 1 (770) 740 0800

fax: 1 (770) 740 8777

email: sales@vsiwaterworks.com



www.VSIWaterworks.com

As part of a process of on-going product development, VSI reserves the right to amend or change specifications without prior notice. Published data may be subject to change. For the latest version, visit our website at www.vsiwaterworks.com