



**SERIES CVI
AWWA C508
SWING CHECK VALVES
2"-48"**



Series CVI

Swing Check Valves
to AWWA C508



LIFTING LUGS & ACCESSORY HOLE

VSI check valve covers come standard with stainless steel lifting lugs for ease of installation and movement in the field. They all also come standard with a tapped plug hole for accessory mounting, such as pressure gauges.

NO FLAT GASKETS

Our replaceable seat check valves come standard with O-rings used in many locations. Here we use an O-ring to seal off the top access port for a long lasting and easily serviceable seal, with replacements available from almost all MRO suppliers.

AMBIDEXTROUS ARM MOUNTING

We offer the ability to mount the outside lever and weight on either side of the valve to fit in tight or unconventional spaces.

REPLACEABLE SEATS

VSI offers these valves with numerous options for seating surfaces. Our rubber and metal seats are field replaceable with common hand tools for ease of service. In the replaceable seat version of the CVI, the rubber seats come standard with a stainless-steel retainer.

VERSATILE BODY SEAT

The body seat is available in multiple material options and is field serviceable also. In the replaceable seat version of the CVI, it is retained by stainless steel hardware.

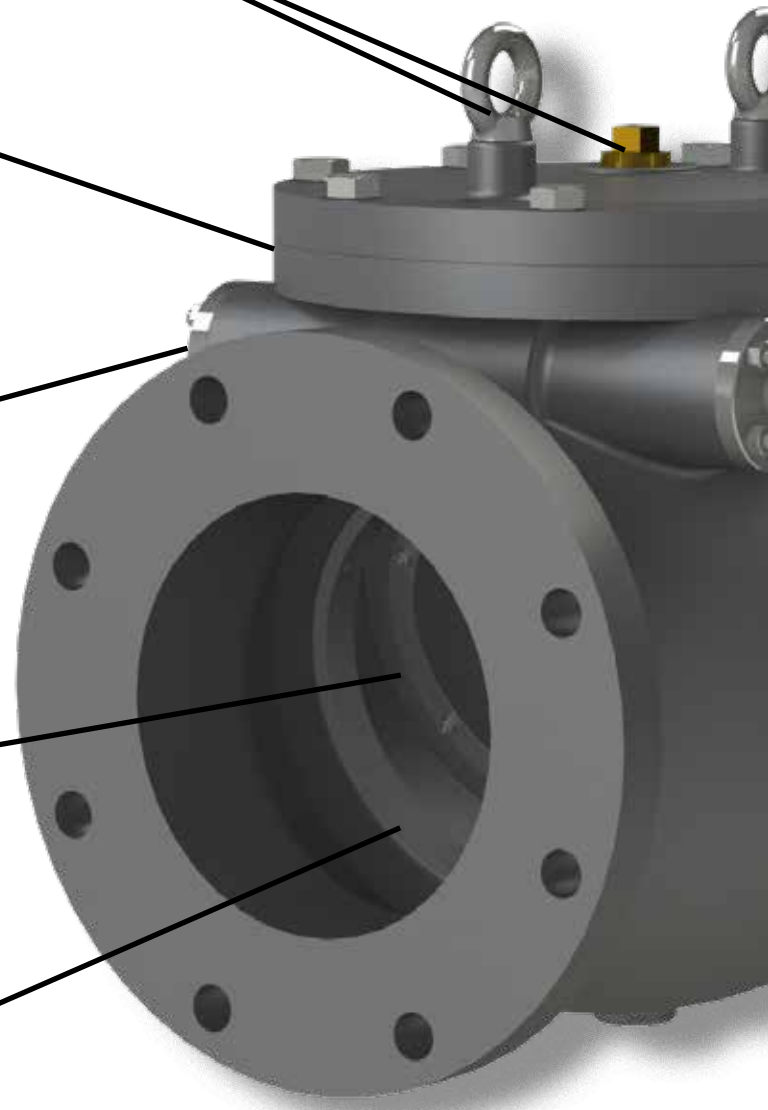

PAGE 2



STAINLESS HARDWARE

Valves come standard with stainless steel 316 hardware for long service life in buried/submerged and harsh service conditions. Additional options available for corrosive and extreme exposures.

SHAFT OPTIONS

The shaft comes standard as stainless steel 17-4PH with many other options for harsh environments. The shaft is sealed on each end with rubber seals backed by stainless steel glands.

HEX MOUNTED LEVER AND WEIGHT

The outside lever and weight is affixed to the shaft via a hex shape with a tightening screw to eliminate all slop and long term wear on the assembly. This also allows for mounting in different angles to facilitate both horizontal and vertical pipe installation.

MOUNTS WITH CUSHIONING OPTIONS

Side mounted air and oil cushioning equipped with limit switches are available on the VSI check valve range. We have custom engineered the cushioning for the CVI to give a sturdy and economical option valve control.

EPOXY COATING

VSI's check valve is fully coated with a 2-part epoxy conforming to AWWA C550.

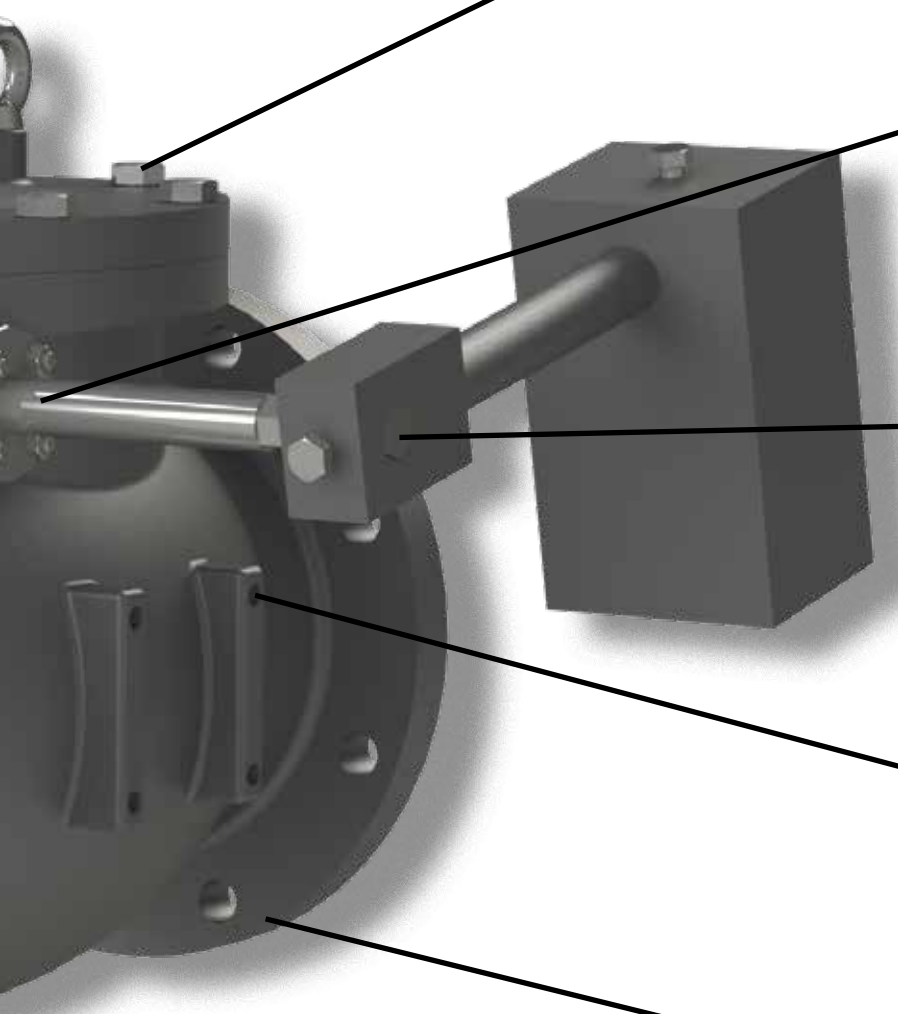

NOTE: VSI offers two versions of the series CVI. All features are not applicable to all valves. Consult with VSI for more information.

Series CVI

Swing Check Valves
to AWWA C508



The VSI Advantage

VSI CHECK VALVE ADVANTAGES

All Series CVI Replaceable Seat Check Valves come standard with the far superior Ductile Iron body and disc. The higher strength of Ductile Iron compared to Cast Iron allows all valves up to 24" to be rated to a full 200 psi or more. By utilizing heavy duty thick wall castings to AWWA C508 standards and modern Ductile Iron as the material, valves are able to have high operating pressures and extended service lives.



Size	AWWA C508	Series CVI
2"-12"	175psi	250psi
14"-24"	150psi	200psi

PAGE 4



EASY TO SERVICE

VSI's series CVI Replaceable Seat Check Valves come with a replaceable rubber or metal disc seat for ease of service in the field. This allows for ease of field maintenance, without removing the valve from the pipeline, when combined with the large top service cover. This also allows for flexibility when picking a resilient seat material - high temperature or other custom seats can be fit and valves shipped the same day in some cases.

As standard, all series CVI Replaceable Seat Check Valves feature a stainless steel 17-4PH shaft. Shafts are able to be placed on either side of the valve allowing for ambidextrous mounting for any tight space and for vertical or horizontal installation. Lever and Weights are mounted securely on a hex end with retaining screw to ensure zero play in the assembly. Many other shaft options are available to meet project requirements.

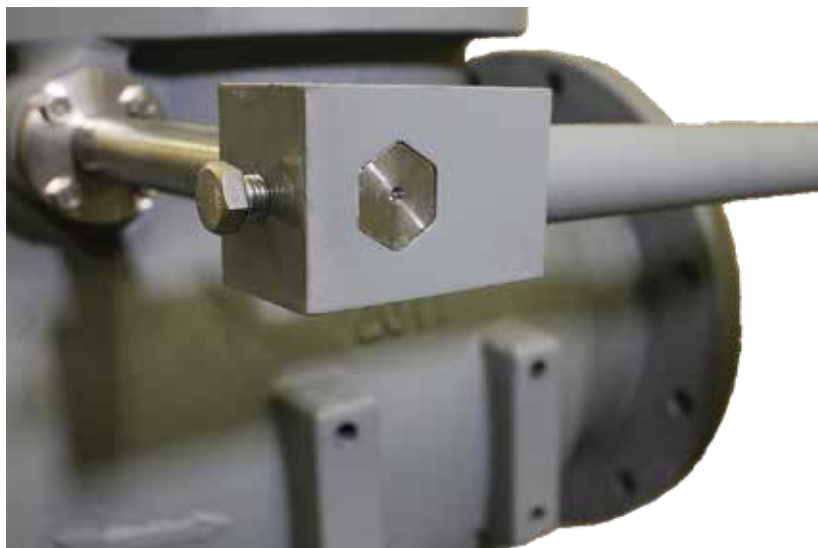

IMPLEMENTATIONS

The Outside Lever and Weight Check Valve has long been the standard for low cost backflow prevention applications. The resilient seated variation of the Check Valve adds the characteristic of zero-leak to this list. The VSI check valve can easily be factory equipped with air/oil cushioning for any application where advanced valve control is necessary.

REPLACEABLE/INTERCHANGEABLE SEAT

The ductile iron disc in the Series CVI features a replaceable resilient seat retained by a single piece stainless steel 316 retaining ring or a single piece replaceable metal seat. The ability to change rubber compounds provides excellent sealing performance, and the ability to accommodate many different line media. Both the body seat and disc seat of metal and resilient seated valves are fully field serviceable.



PAGE 5



AIR AND OIL CUSHION OPTIONS

The VSI check valve can easily be factory equipped with air/oil cushioning for any application where advanced valve control is necessary. We have engineered our custom fabricated cushioning assemblies for each of our valves sizes to produce the most cost effective and reliable products. Limit switches for remote valve position signaling are also available.

NOTE: VSI offers two versions of the series CVI. All features are not applicable to all valves. Consult with VSI for more information.



SAMPLE SPECIFICATION

Series CVI Replaceable Seat Swing Check Valves for Waterworks Service

- 1.1. This specification covers the design, manufacture, and testing of cast resilient and metal seated swing check valves 2 inch (75 mm) and larger under service pressure of up to 250 psig (1724 kPa).
- 1.2. Swing check valves shall be resilient or metal seated and of the outside lever and weight configuration.
2. GOVERNING STANDARDS
 - 2.1. All swing check valves shall be in full conformance with the design, manufacturing, and testing standards set forth by the American Water Works Association (AWWA) in Standard ANSI/AWWA C508.
3. CONNECTIONS
 - 3.1. Flanged valves shall conform to all standards of ANSI B16.1, Class 125 or Class 250.
 - 3.2. Flanged valves' lay length shall conform to ANSI/AWWA C508 Full Lay Length.
4. MARKINGS
 - 4.1. Each valve shall be marked with the manufacturer's name, valve size, body material, and pressure rating cast into the body of the valve. Lettering shall be a minimum of 1/2 inch-tall and project 1/10 inch from body.
 - 4.2. When requested swing check valves, shall be equipped with a tag identifying body, seat, and shaft material in addition to manufacturer's name, pressure rating, size, date of manufacturer, and date of testing.
5. DESIGN
 - 5.1. Valves shall be equipped with a rubber or metal seat, retained by stainless steel socket head cap screws.
 - 5.2. Valve shaft shall be made of stainless steel 304 at a minimum. It shall have bronze bushings and NBR seal rings on each end. Shaft shall be capable of being extended to either side of the valve.
 - 5.3. Valves shall be equipped with an O-ring sealing the top access port.
 - 5.4. Removable pins shall hold the shaft in place laterally. Use of retaining collars will not be permitted.
 - 5.5. The valve should have a smooth waterway equal to 100% ±5% the nominal pipe size.
 - 5.6. Valve seats shall be field serviceable using no manufacture specific or custom tool.
 - 5.7. Valves are designed for horizontal installation where the gravity will pull the valve closed with no flow. If valve is to be installed in vertical pipe the manufacture shall be informed at time of order.
 - 5.8. The valves shall be equipped with a mounting pad on both sides of the valve body for attaching flow control and position relaying accessories such as but not limited to; pneumatic cylinders for air cushioning, hydraulic cylinders for oil cushioning, or limit switches for open or closed position sensing.
 - 5.9. Flange dimensions and drilling should conform to ANSI/ASME B16.1 class 125 unless explicitly specified otherwise.
 - 5.10. Valves shall provide a bubble-tight shutoff for rubber seated valves at rated working pressure. Allowable leakage for metal seated valves is 1 oz/in/hr.
6. MATERIALS
 - 6.1. The valve body, and disc shall be constructed of ASTM A536 Ductile Iron.
 - 6.2. The rubber disc seat shall be made from a replaceable ring of resilient NBR or EPDM as specified. The metal disc seat shall commonly be made of either stainless steel 316 or bronze, with other materials available.
 - 6.3. The stem shall be made of ASTM A693 type 17-4PH stainless steel, or ASTM A276 type 304 or 316 stainless steel as specified.
 - 6.4. Shaft bearings shall be made of lead free Bronze conforming to ASTM B16.
 - 6.5. All coatings shall conform to AWWA C550, be holiday free, and have a minimum total dry film thickness of 10 mils.
 - 6.6. All valves shall have type 304 or 316 stainless steel interior and exterior hardware.
7. FLOW CONTROL OPERATORS
 - 7.1. All valves equipped with side mounted air/oil cushions will be mounted using stainless hardware and coated carbon steel fabricated bracket and arm unless otherwise specified.
 - 7.2. All cylinders are ISO 15552 with aluminum bodies and chrome plated steel rods, with stainless steel available upon request.
 - 7.3. Oil reservoirs are to be mounted above the cylinder with an air valve pressurizing the system.
 - 7.4. Limit switched may be mounted to the cylinders upon request for open and closed signaling.
8. MANUFACTURER
 - 8.1. Swing check valves shall be VSI Series CVI as manufactured by Valve Solutions, Inc., Alpharetta, GA USA.
 - 8.2. All valves shall be warranted by manufacturer for a minimum of 12 months.



STANDARD MATERIALS OF CONSTRUCTION METAL SEATED

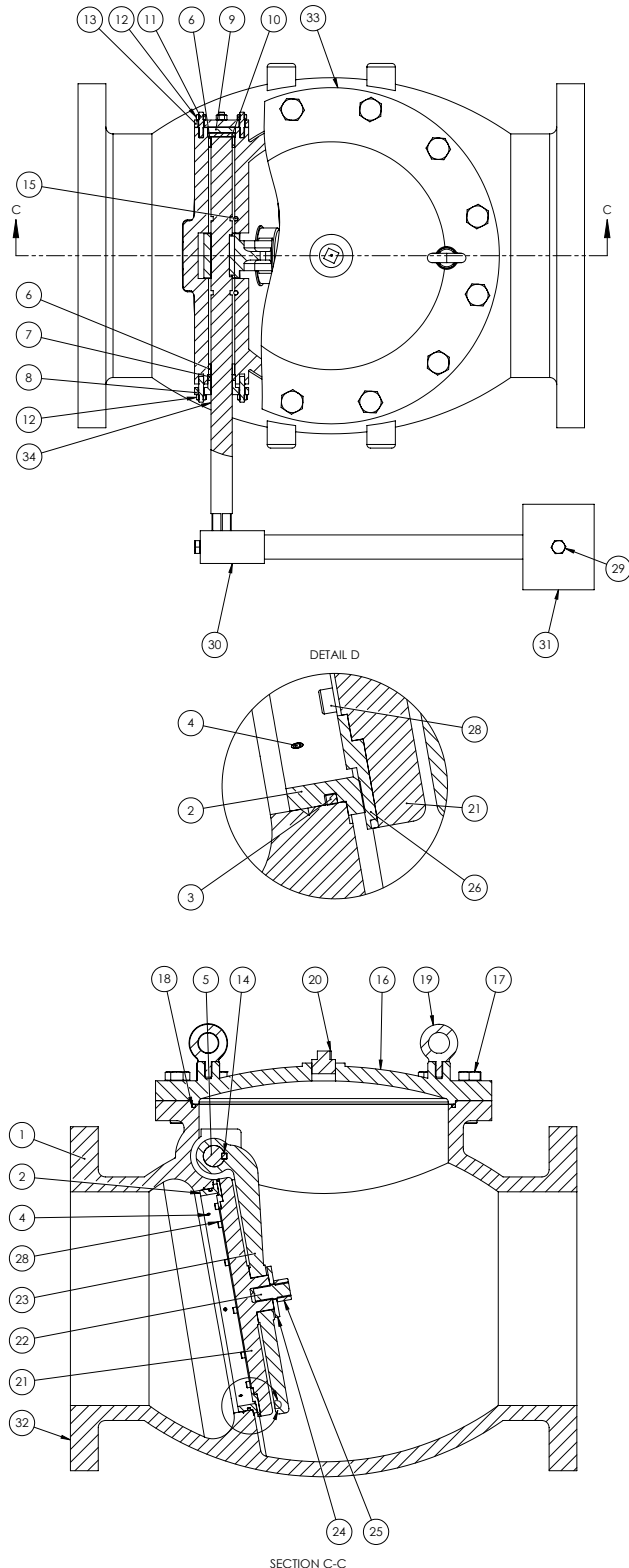

ITEM	DESCRIPTION	MATERIAL
1	BODY	DUCTILE IRON ASTM A536 65-45-12
2	BODY SEAT	BRONZE ASTM B584 C83600
3	O-RING	NBR
4	BODY SEAT SCREW	STAINLESS ASTM F593/F594 GROUP 2
5	SHAFT	STAINLESS 17-4PH ASTM A693
6	BUSHING	BRONZE ASTM B16
7	PACKING	PTFE
8	GLAND	AISI 316
9	SEAL	NBR
10	PLUG	AISI 316
11	STUD	STAINLESS ASTM F593/F594 GROUP 2
12	HEX NUT	STAINLESS ASTM F593/F594 GROUP 2
13	END COVER	AISI 316
14	KEY	AISI 316
15	FIXING PIN	AISI 316
16	COVER	DUCTILE IRON ASTM A536 65-45-12
17	HEX BOLT	STAINLESS ASTM F593/F594 GROUP 2
18	COVER O-RING	NBR
19	LIFTING EYE	COATED STEEL
20	PIPE PLUG	BRASS
21	DISC	DUCTILE IRON ASTM A536 65-45-12
22	DISC STUD	STAINLESS ASTM F593/F594 GROUP 2
23	INNER ARM	DUCTILE IRON ASTM A536 65-45-12
24	FLAT WASHER	STAINLESS ASTM F593/F594 GROUP 2
25	CASTLE NUT/COTTER PIN	STAINLESS ASTM F593/F594 GROUP 2
26	DISC SEAT	BRONZE ASTM B584 C83600
28	SH CAP SCREW	STAINLESS ASTM F593/F594 GROUP 2
29	HEX BOLT	STAINLESS ASTM F593/F594 GROUP 2
30	LEVER	COATED STEEL
31	COUNTER WEIGHT	COATED STEEL
32	COATING	AWWA C550 2-PART EPOXY
33	TAG	ALUMINUM
34	ASSEMBLY LUBE	DOW CORNING 111 OR EQUAL (NSF)

Part number - CVIxxF-DD6BB-B31/O
Additional material options available as special order.

NOTE: VSI offers two versions of the series CVI. All features are not applicable to all valves. Consult with VSI for more information.



STANDARD MATERIALS OF CONSTRUCTION RUBBER SEATED

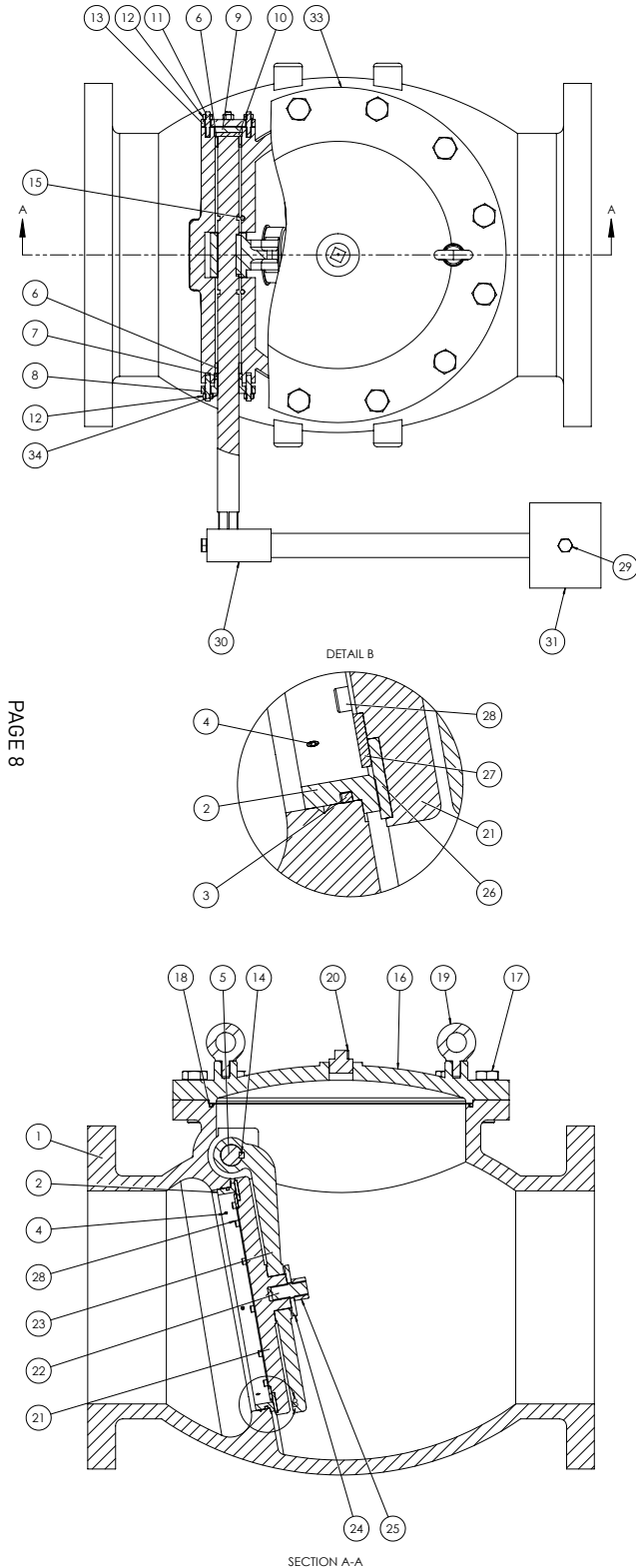

ITEM	DESCRIPTION	MATERIAL
1	BODY	DUCTILE IRON ASTM A536 65-45-12
2	BODY SEAT	STAINLESS 316 ASTM A276
3	O-RING	NBR
4	BODY SEAT SCREW	STAINLESS ASTM F593/F594 GROUP 2
5	SHAFT	STAINLESS 17-4PH ASTM A693
6	BUSHING	BRONZE ASTM B16
7	PACKING	PTFE
8	GLAND	AISI 316
9	SEAL	NBR
10	PLUG	AISI 316
11	STUD	STAINLESS ASTM F593/F594 GROUP 2
12	HEX NUT	STAINLESS ASTM F593/F594 GROUP 2
13	END COVER	AISI 316
14	KEY	AISI 316
15	FIXING PIN	AISI 316
16	COVER	DUCTILE IRON ASTM A536 65-45-12
17	HEX BOLT	STAINLESS ASTM F593/F594 GROUP 2
18	COVER O-RING	NBR
19	LIFTING EYE	COATED STEEL
20	PIPE PLUG	BRASS
21	DISC	DUCTILE IRON ASTM A536 65-45-12
22	DISC STUD	STAINLESS ASTM F593/F594 GROUP 2
23	INNER ARM	DUCTILE IRON ASTM A536 65-45-12
24	FLAT WASHER	STAINLESS ASTM F593/F594 GROUP 2
25	CASTLE NUT/COTTER PIN	STAINLESS ASTM F593/F594 GROUP 2
26	DISC SEAT	BUNA-N(NBR)
27	DISC SEAT RETAINER	STAINLESS 316 ASTM A276
28	SH CAP SCREW	STAINLESS ASTM F593/F594 GROUP 2
29	HEX BOLT	STAINLESS ASTM F593/F594 GROUP 2
30	LEVER	COATED STEEL
31	COUNTER WEIGHT	COATED STEEL
32	COATING	AWWA C550 2-PART EPOXY
33	TAG	ALUMINUM
34	ASSEMBLY LUBE	DOW CORNING 111 OR EQUAL (NSF)

Part number - CVIxxF-DD63N-B31/O
Additional material options available as special order.



DESIGN STANDARDS

Size Range	6"-48" Flanged End
Construction	AWWA C508 ASME B16.34 API 600
Coatings	AWWA C550*
Connections	ANSI B16.1 Class 125* ANSI B16.1 Class 250 ANSI B16.5 Class 150 ANSI B16.5 Class 300
Lay Length	AWWA C508 Appendix A Full ISO 5752
Classifications	150 PSIG 175 PSIG 200 PSIG* 250 PSIG*



American Water Works
Association

*Standard Option

RESISTANCE GUIDE

Designation	Common Names	Composition	Min/Max Temperature Range	General Properties	Resistant to:	Attached by:
EPDM	EPDM, EPM	Ethylene-propylene-diene Monomer	-40F/250F	Excellent ozone, chemical, and aging resistance. Poor resistance to petroleum-based fluids	Animal and vegetable oils, ozone, strong and oxidizing chemicals.	Mineral oils and solvents, aromatic hydrocarbons
NBR	NBR, Buna-N	Nitrile-butadiene	-30F/225F	Excellent resistance to petroleum-based fluids. Good physical properties	Many hydrocarbons, fats, oils, greases, hydraulic fluids, chemicals	Ozone, ketones, esters, aldehydes, chlorinated and nitro hydrocarbons
FPM	FPM, Viton®	Hexafluoropropylene-vinylidene fluoride	-10F/400F	Excellent oil and air resistances both at low and high temperatures. Very good chemical resistance	All aliphatic, aromatic, and halogenated hydrocarbons, acids, animal and vegetable oils	Ketones, low molecular weight esters and nitro containing compounds
PTFE	PTFE, Teflon®	Polytetrafluoro-ethylene	-100F/450F	Excellent abrasion resistance and chemically inert	Acids, harsh inorganic and organic chemicals, oils, oxidizing agents, and solvents	Molten alkali metals and fluorine at high temperatures

NOTE: VSI offers two versions of the series CVI. All features are not applicable to all valves. Consult with VSI for more information.



PRESSURE/TEMPERATURE RATINGS

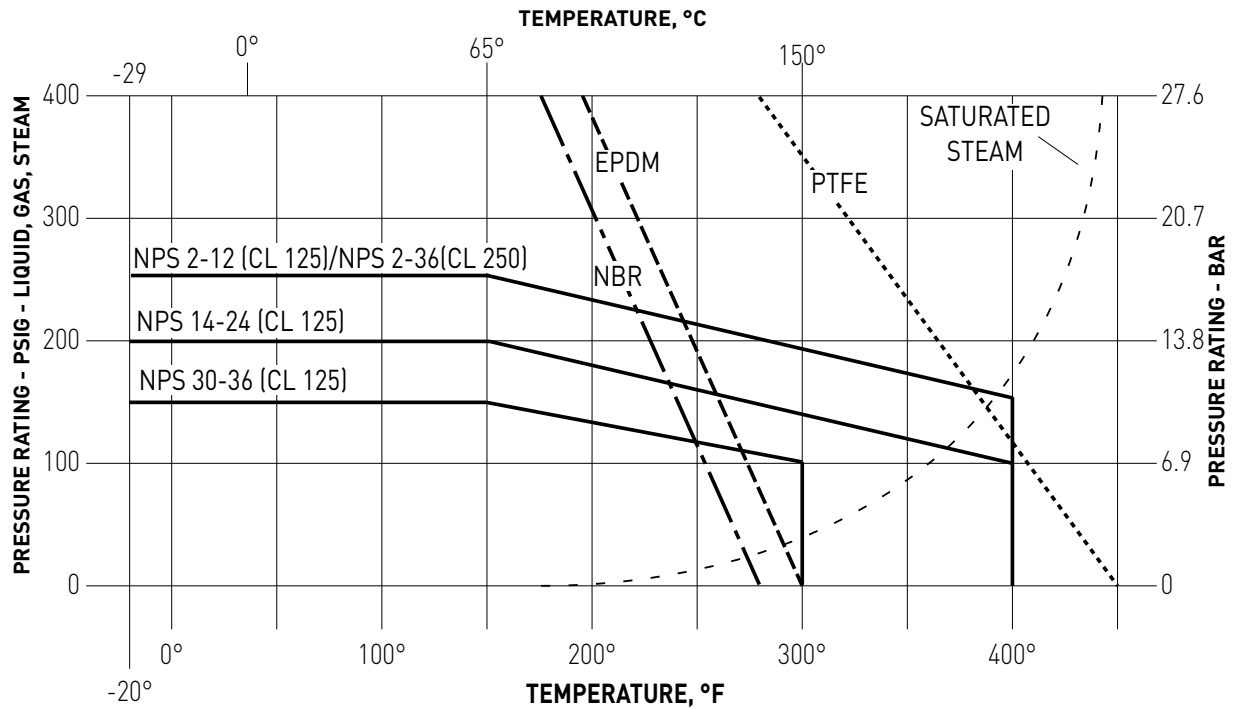

In determining field pressure ratings for Series CVI Check Valves that are constructed of Ductile Iron the above chart should be used. Pressure cast on valve represents maximum seating pressure; maximum hydrostatic pressure is temperature dependent, and may be higher than nominal pressure rating.



CVI HEAD LOSS CHART

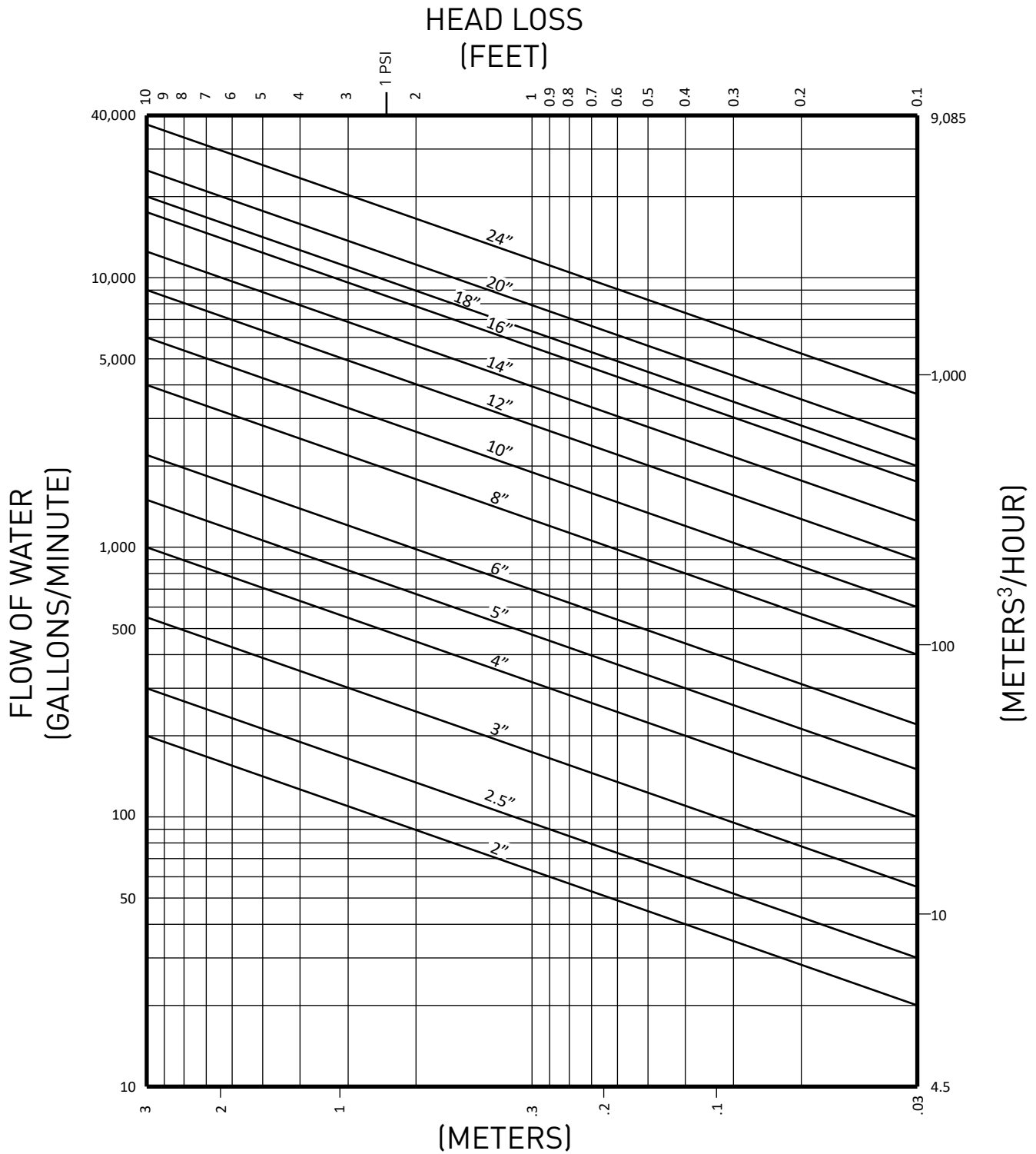

NPS	2	2.5	3	4	5	6	8	10	12	14	16	18	20	24
Cv	101	152	265	495	735	1120	1895	2992	4475	6008	8478	9835	1385	1865
K	1.40	1.50	1.56	1.62	1.07	1.61	1.58	1.56	1.54	1.56	1.59	1.57	1.55	1.49

NOTE: VSI offers two versions of the series CVI. All features are not applicable to all valves. Consult with VSI for more information.



FLANGED WITH OUTSIDE LEVER AND WEIGHT

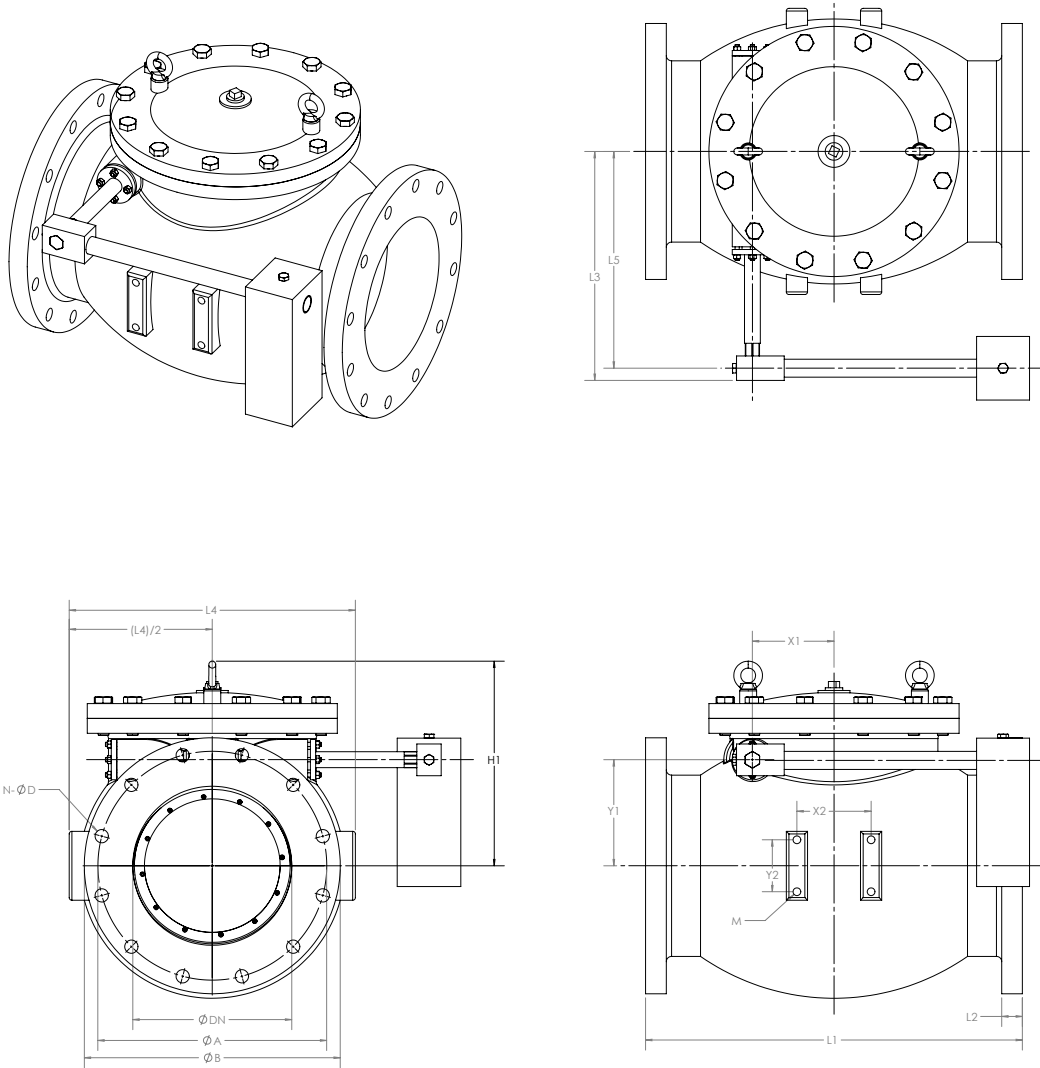

PAGE 12

SIZE	ØA	ØB	H1	L1	L2	L3	L4	L5	N	ØD	X1	X2	Y1	Y2	M	WEIGHT (Lbs.)
4"	7.50	9.0	8.5	11.5	0.94	8.4	8.8	7.2	8	0.75	2.1	1.73	3.3	2.44	M12	102
6"	9.50	11.0	9.0	14.0	1.00	12.0	11.8	10.6	8	0.87	3.3	2.28	4.6	2.76	M12	165
8"	11.75	13.5	12.0	19.5	1.12	14.0	14.6	12.6	8	0.87	4.2	2.36	5.6	3.31	M12	308
10"	14.25	16.0	14.0	24.5	1.19	15.0	16.9	13.6	12	0.98	5.9	2.40	6.9	3.70	M12	450
12"	17.00	19.0	16.0	27.5	1.38	17.0	21.3	15.6	12	0.98	6.1	5.51	7.9	3.86	M16	653
14"	18.75	21.0	22.0	31.0	1.38	17.0	22.6	15.6	12	1.14	7.2	5.51	8.9	3.86	M16	1150
16"	21.25	23.5	23.0	36.0	1.44	24.0	26.4	22.6	16	1.14	8.1	4.84	10.6	4.25	M16	1500
18"	22.75	25.0	24.0	40.0	1.56	24.0	28.5	22.6	16	1.26	9.8	6.30	12.0	4.65	M16	1820
20"	25.00	27.5	24.0	40.0	1.69	28.0	30.7	26.4	20	1.26	10.4	6.30	13.2	5.83	M16	1942
24"	29.50	32.0	34.0	48.0	1.88	33.5	35.8	31.9	20	1.38	12.0	5.51	15.3	6.46	M16	3100

NOTE: VSI offers two versions of the series CVI. All features are not applicable to all valves. Consult with VSI for more information.



FLANGED WITH SIDE MOUNTED AIR CUSHION

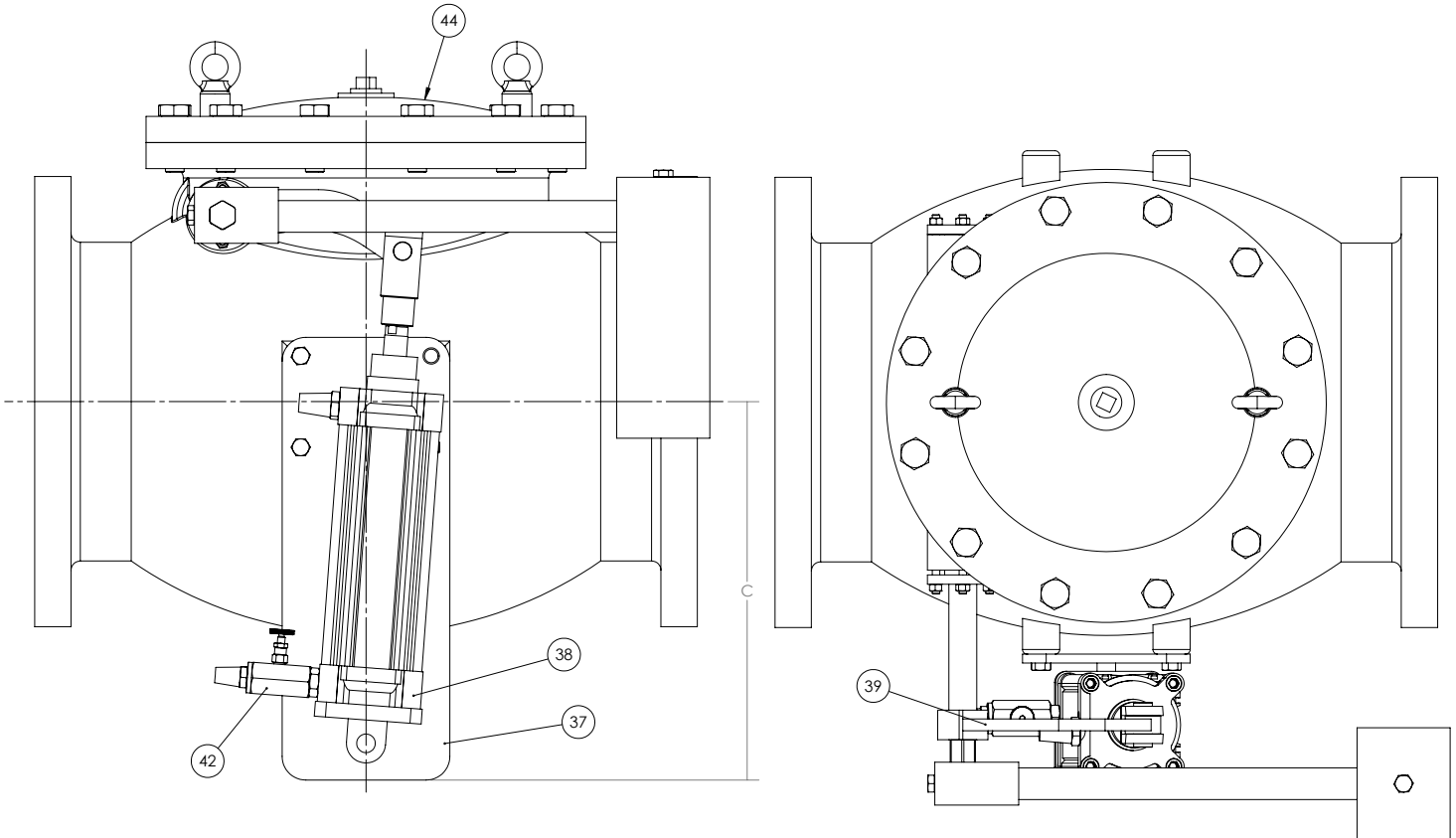

PAGE 13

ITEM NO.	PART DESCRIPTION	QTY	SIZE	C (Inches)
37	STEEL CUSHION BRACKET	1	6"	15.90
38	ALUMINUM PNEUMATIC CYLINDER	1	8"	15.25
39	STEEL CUSHION ARM	1	10"	17.10
42	BRASS FITTINGS AND CONTROL VALVE	1	12"	15.95
44	CVI VALVE ASSEMBLY	1	14"	15.00
			16"	20.25

*Consult with factory for cushioned assemblies smaller than 4" and larger than 16".

*Vertical install applications require a different bracket, consult with factory.

*Custom shorter brackets are available upon request in some sizes.

NOTE: VSI offers two versions of the series CVI. All features are not applicable to all valves. Consult with VSI for more information.



REPLACEABLE SEAT PART NUMBER MATRIX

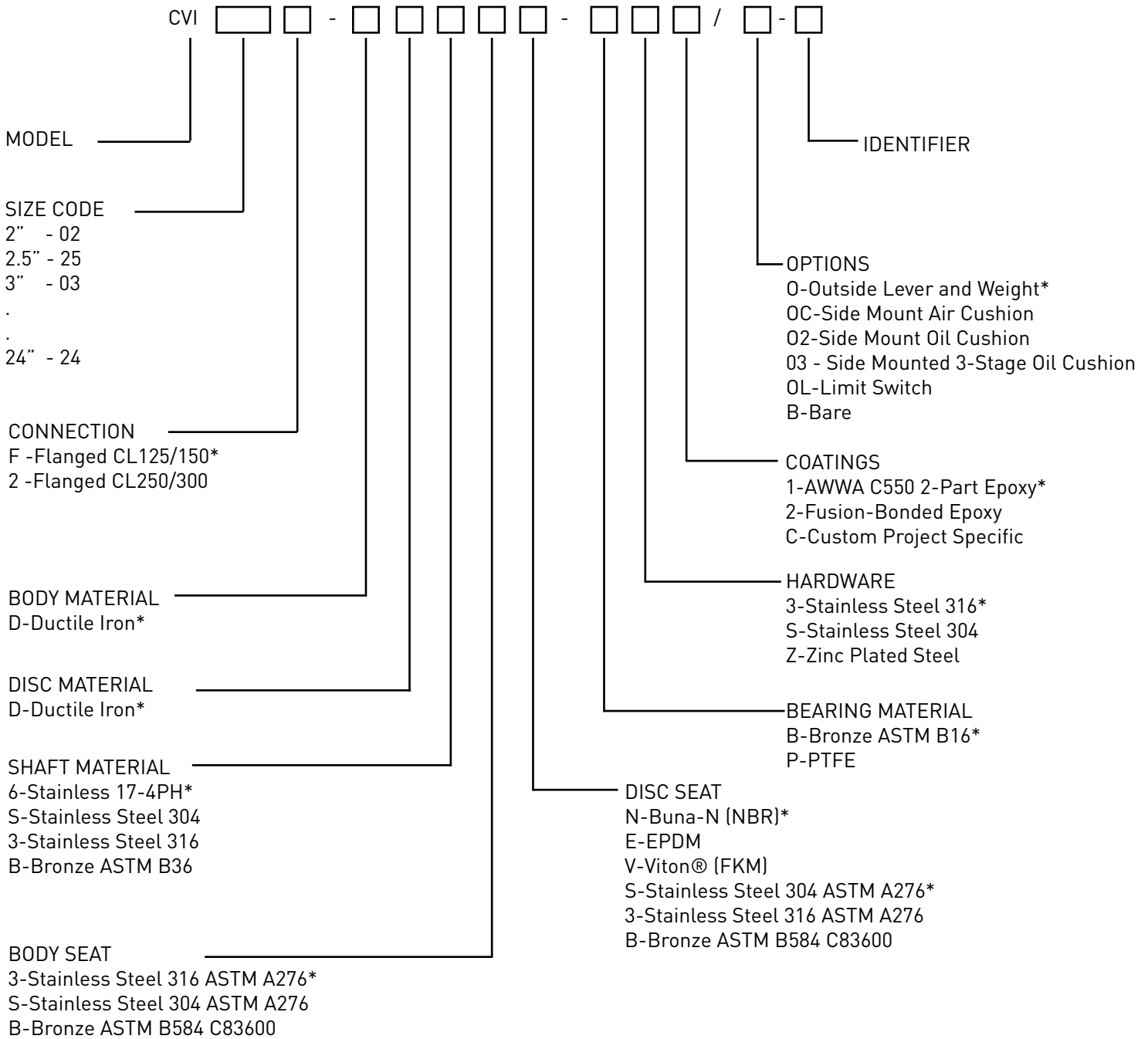

PAGE 14

* Standard Material
Additional material options available as special order.

EXAMPLE:
CVI08F-DD63N-B31/O-Q
A 8" flanged Check valve with Ductile Iron body and disc, SS 17-4PH shaft, SS316 body seat, NBR disc seat and seals, bronze bearings, SS316 hardware, AWWA C550 2-part epoxy coatings with outside lever & weight.



2"-48" CVI BONDED SEAT SWING CHECK

BONDED SEAT SWING CHECK VALVE

VSI offers the simplified bonded seat type check valve for pump and lift stations where a standard duty valve is acceptable and external accessories are not required. It still exemplifies VSI's commitment to providing a quality product.

- Body seats are permanently bonded non-replaceable, reducing possible leakage paths.
- Disc seats are replaceable by way of replacing the entire disc.
- The shaft extends only to one side, reducing seal friction and possible leakage paths.



SIMPLE INTERNALS

VSI Bonded Seat Swing Check Valves are built with simplicity in mind for use in general duty applications. They feature minimal internal hardware and robust coatings for long service life in many less demanding applications.

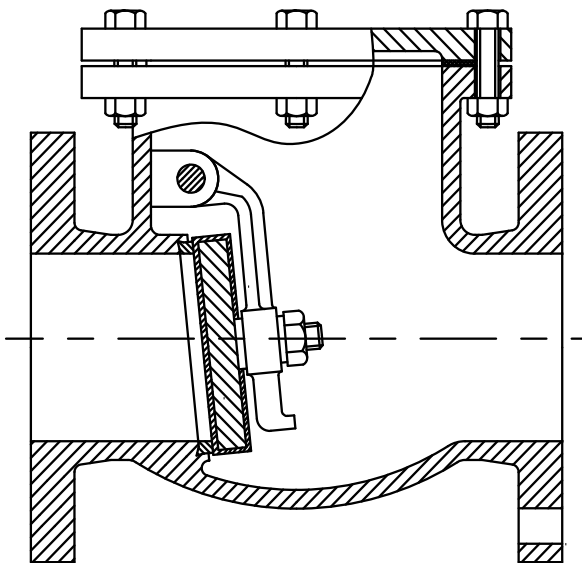

REPLACEABLE DISC

VSI Swing Check Valves incorporate a replaceable bonded seat, which can be removed without taking the valve out from the line. Simply remove the sealed cover, and change out the entire disc.

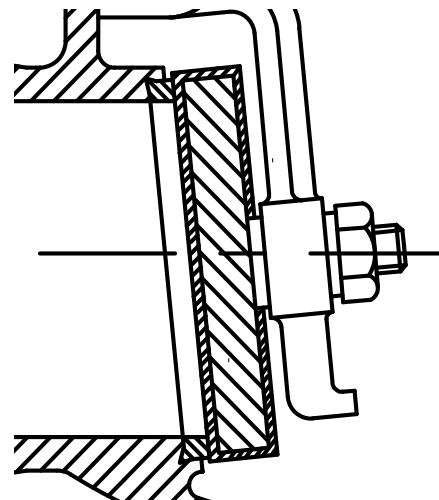

NOTE: VSI offers two versions of the series CVI. All features are not applicable to all valves. Consult with VSI for more information.



MATERIALS OF CONSTRUCTION METAL SEATED VALVES

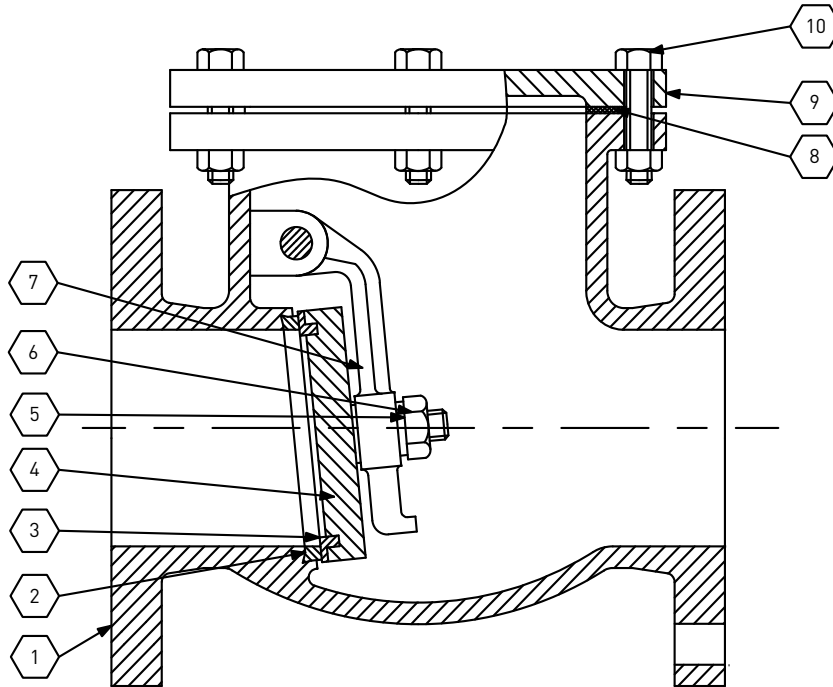
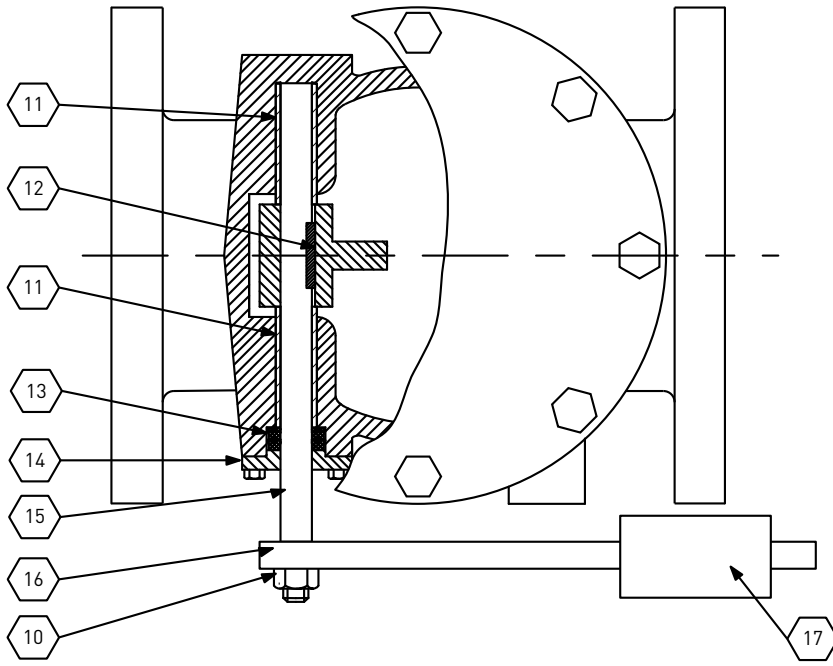

ITEM	DESCRIPTION	MATERIAL OPTIONS
1	BODY	DUCTILE IRON ASTM A536 65-45-12
2	BODY SEAT RING	STAINLESS 304 ASTM A276
		STAINLESS 316 ASTM A276
		BRONZE ASTM B62
3	DISC SEAT RING	STAINLESS 304 ASTM A276
		STAINLESS 316 ASTM A276
		BRONZE ASTM B62
4	DISC	DUCTILE IRON ASTM A536 65-45-12
5	WASHER	STEEL ASTM A36
6	WETTED HARDWARE	STAINLESS ASTM F593 GROUP 1
		STAINLESS ASTM F593 GROUP 2
		STEEL ASTM A325 TYPE 1
7	ARM	DUCTILE IRON ASTM A536 65-45-12
8	SEAL	EPDM
		BUNA-N (NBR)
9	COVER	SAME AS BODY (1)
10	EXTERIOR HARDWARE	STAINLESS ASTM F593 GROUP 1
		STAINLESS ASTM F593 GROUP 2
		STEEL ASTM A325 TYPE 1
11	BEARING	PTFE
12	KEY	STEEL ASTM A36
13	SHAFT SEAL	EPDM
		BUNA-N (NBR)
14	RETAINER	SAME AS BODY (1)
15	SHAFT	STAINLESS 304 ASTM A276
		STAINLESS 316 ASTM A276
		STAINLESS 17-4PH ASTM A693
16	ARM*	DUCTILE IRON ASTM A536 65-45-12
17	WEIGHT*	DUCTILE IRON ASTM A536 65-45-12

* IF EQUIPPED



MATERIALS OF CONSTRUCTION RUBBER SEATED

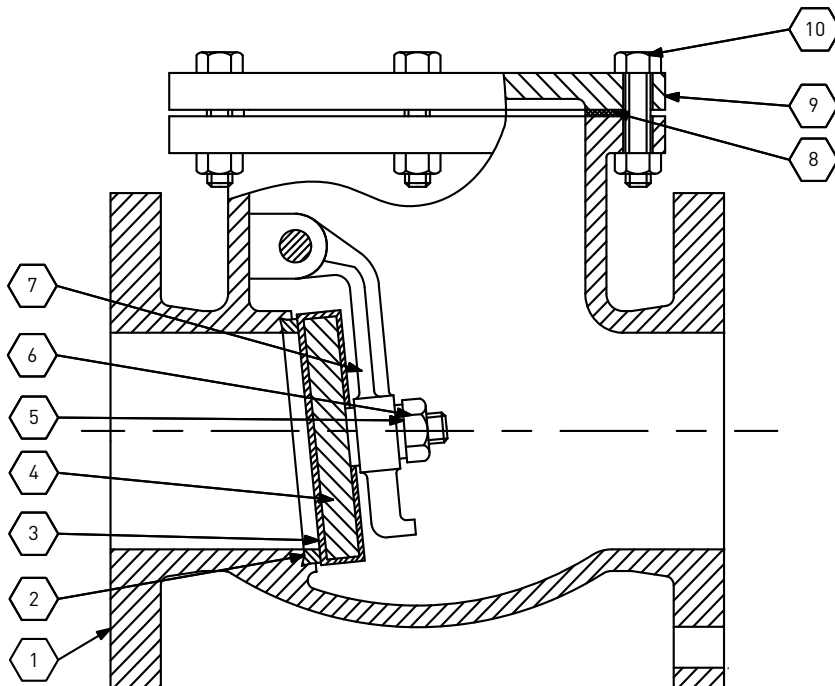
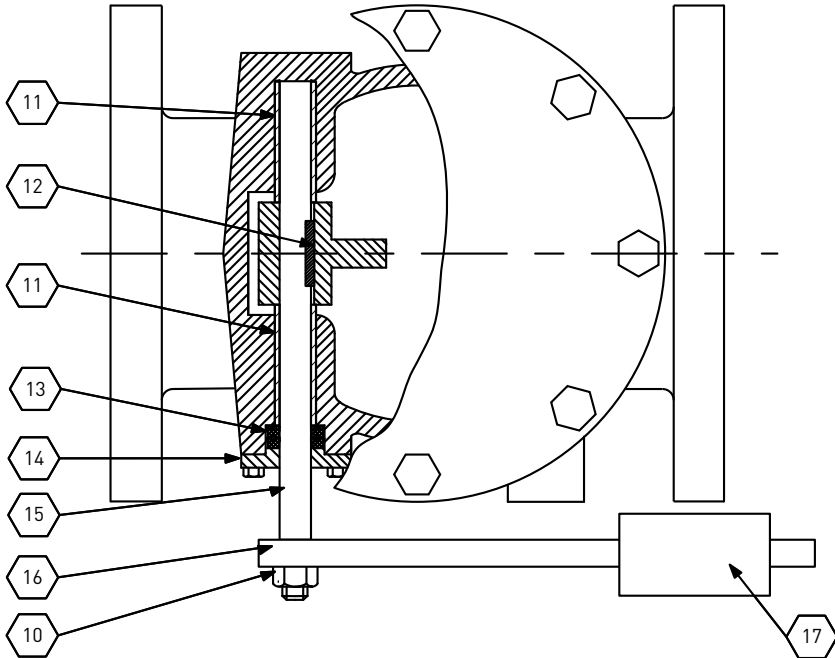

ITEM	DESCRIPTION	MATERIAL OPTIONS
1	BODY	DUCTILE IRON ASTM A536 65-45-12
2	BODY SEAT RING	STAINLESS 304 ASTM A276
		STAINLESS 316 ASTM A276
		BRONZE ASTM B62
3	DISC SEAT	EPDM
		BUNA-N (NBR)
		VITON (FPM)
4	DISC	DUCTILE IRON ASTM A536 65-45-12
5	WASHER	STEEL ASTM A36
6	WETTED HARDWARE	STAINLESS ASTM F593 GROUP 1
		STAINLESS ASTM F593 GROUP 2
		STEEL ASTM A325 TYPE 1
7	ARM	DUCTILE IRON ASTM A536 65-45-12
8	SEAL	EPDM
		BUNA-N (NBR)
9	COVER	SAME AS BODY (1)
10	EXTERIOR HARDWARE	STAINLESS ASTM F593 GROUP 1
		STAINLESS ASTM F593 GROUP 2
		STEEL ASTM A325 TYPE 1
11	BEARING	PTFE
12	KEY	STEEL ASTM A36
13	SHAFT SEAL	EPDM
		BUNA-N (NBR)
14	RETAINER	SAME AS BODY (1)
15	SHAFT	STAINLESS 304 ASTM A276
		STAINLESS 316 ASTM A276
		STAINLESS 17-4PH ASTM A693
16	ARM*	DUCTILE IRON ASTM A536 65-45-12
17	WEIGHT*	DUCTILE IRON ASTM A536 65-45-12

* IF EQUIPPED

Series CVI

Swing Check Valves
to AWWA C508



FLANGED WITH OUTSIDE LEVER AND WEIGHT

SIZE	A	B	C	D	E	F	WEIGHT (LBS)
2"	8.00	5.4	4.75	6.0	4	0.75	37
2.5"	8.50	5.8	5.5	7.0	4	0.75	44
3"	9.50	6.3	6.00	7.2	4	0.75	51
4"	11.50	7.1	7.50	9.0	8	0.75	79
5"	13.00	8.0	8.50	10.0	8	0.75	101
6"	14.00	8.8	9.50	11.0	8	0.88	128
8"	19.50	10.2	11.75	13.5	8	0.88	238
10"	24.50	11.4	14.25	16.0	12	1.00	374
12"	27.50	12.8	17.00	19.0	12	1.00	418
14"	31.00	16.7	18.74	21.0	12	1.13	737
16"	36.00	17.5	21.25	23.5	16	1.13	968
18"	38.00	18.9	22.75	25.0	16	1.25	1500
20"	42.00	20.7	25.00	27.5	20	1.25	1600
24"	48.00	23.9	29.50	32.0	20	1.38	2600
30"	56.00	28.6	36.00	38.8	28	1.38	-
36"	63.00	37.0	42.75	46.0	32	1.63	-
42"	70.00	41.0	49.50	53.0	36	1.63	-
48"	76.00	49.0	56.00	49.5	44	1.63	-

PAGE 18

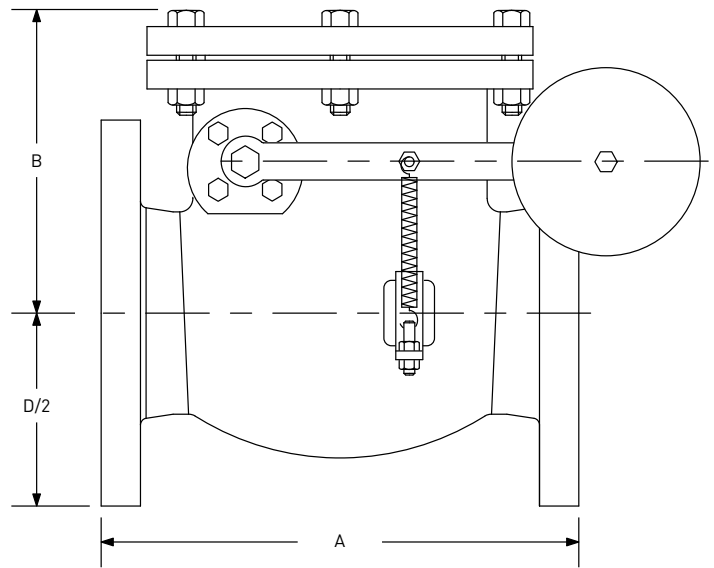
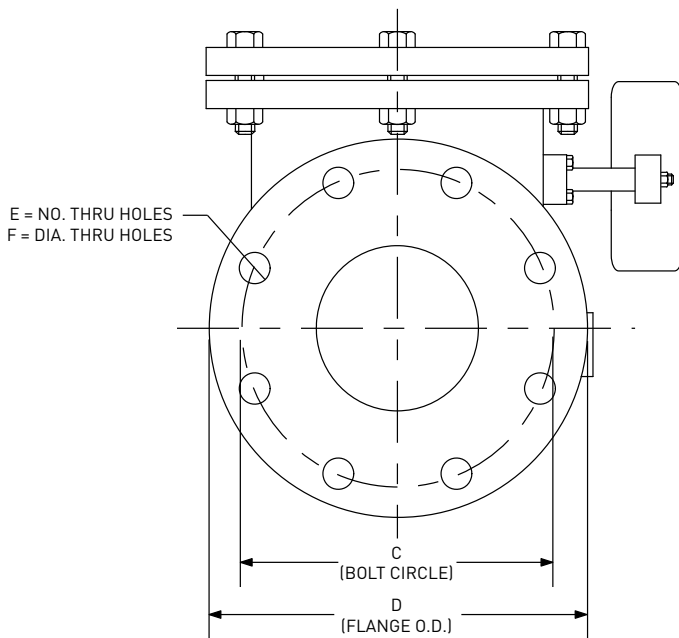



BONDED SEAT SWING CHECK PART NUMBER MATRIX

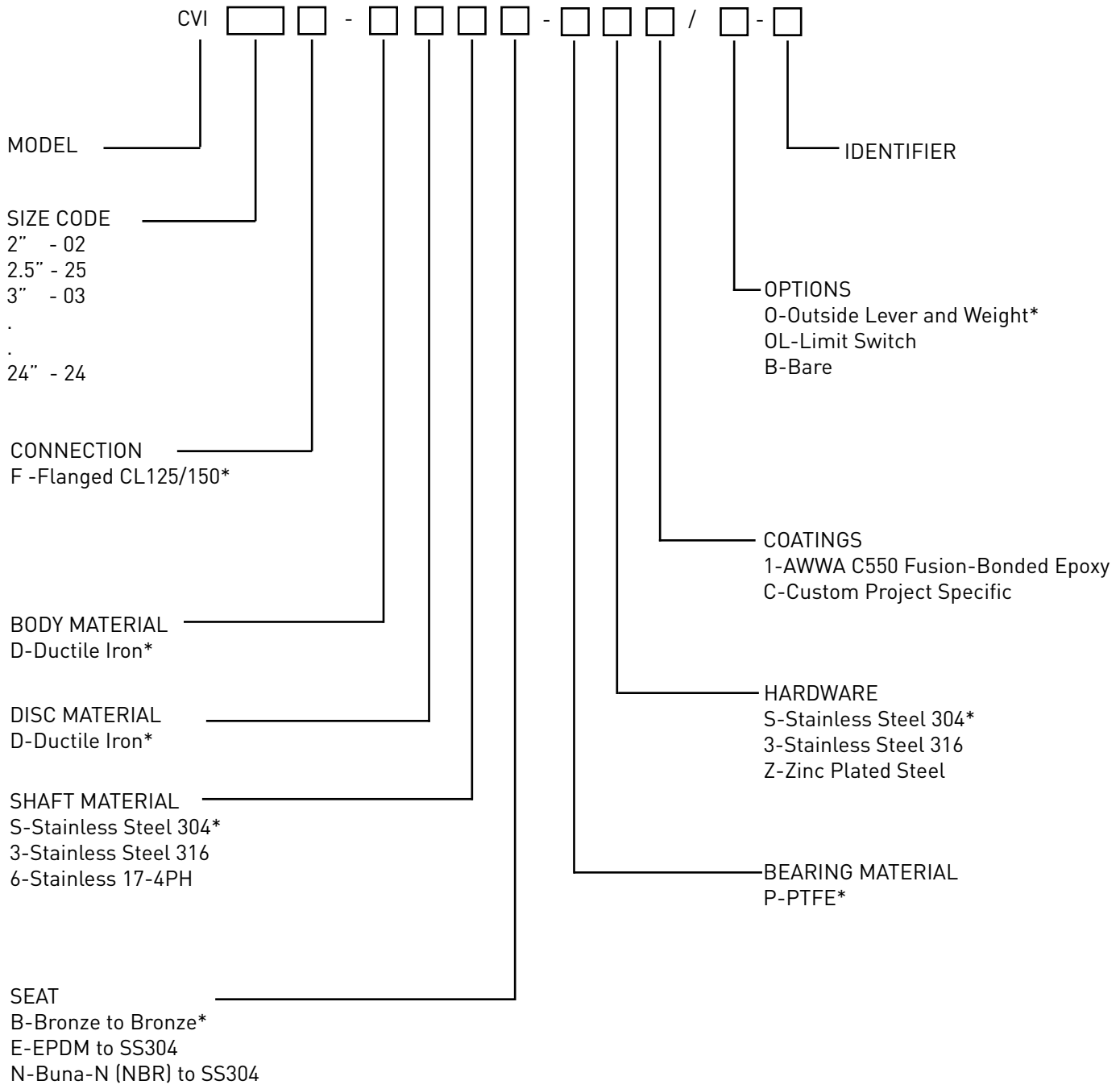

* Standard Material

EXAMPLE:

CVI08F-DDSB-PS1/O-Q

A 8" flanged Check valve with Ductile Iron body and disc, SS304 shaft, Bronze body seat, Bronze disc seat and NBR seals, PTFE bearings, SS304 hardware, AWWA C550 2-part epoxy coatings with outside lever & weight.

NOTE: VSI offers two versions of the series CVI. All features are not applicable to all valves. Consult with VSI for more information.

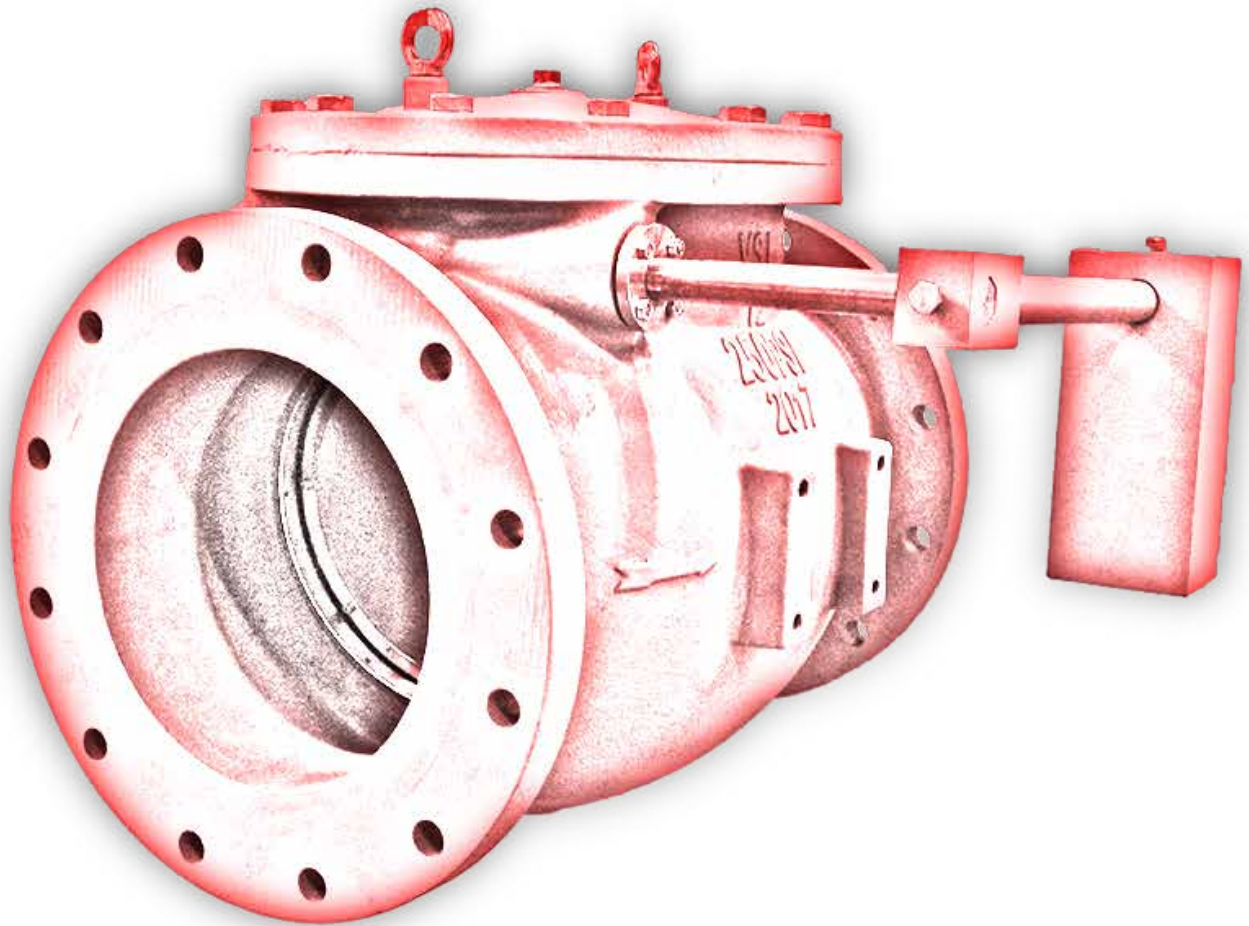

VSI Waterworks LLC

tel: 1 (770) 740 0800

fax: 1 (770) 740 8777

email: sales@vsiwaterworks.com



www.VSIWaterworks.com

As part of a process of on-going product development, VSI reserves the right to amend or change specifications without prior notice. Published data may be subject to change. For the latest version, visit our website at www.vsiwaterworks.com