

VALVE SIZE		A	B	C	D	E
NPS	DN					
2	50	8.00	4.75	6.0	4	0.75
2.5	65	8.50	5.50	7.0	4	0.75
3	75	9.50	6.00	7.5	4	0.75
4	100	11.50	7.50	9.0	8	0.75
5	125	13.00	8.50	10.0	8	0.88
6	150	14.00	9.50	11.0	8	0.88
8	200	19.50	11.75	13.5	8	0.88
10	250	24.50	14.25	16.0	12	1.00
12	300	27.50	17.00	19.0	12	1.00
14	350	31.00	18.74	21.0	12	1.13
16	400	36.00	21.25	23.5	16	1.13
18	450	38.00	22.75	25.0	16	1.25
20	500	38.50	25.00	27.5	20	1.25
24	600	51.00	29.50	32.0	20	1.38

ITEM	DESCRIPTION	MATERIALS	TRIM
1	BODY	DUCTILE IRON ASTM A536 65-45-12	
		CAST IRON ASTM A126 CLASS B	
		STAINLESS ASTM A351 CF8	
		STAINLESS ASTM A351 CF8M	
		CARBON STEEL ASTM A216 WCB	
2	SEAL	EPDM	
		BUNA-N (NBR)	
		VITON (FPM)	
3	COVER	SAME AS BODY (1)	
4	EXTERIOR HARDWARE	STAINLESS ASTM F593 GROUP 1	
		STAINLESS ASTM F593 GROUP 2	
		STEEL ASTM A325 TYPE 1	
5	REINFORCEMENT	DUCTILE IRON ASTM A536 65-45-12	
6	ENCAPSULATION	EPDM	
		BUNA-N (NBR)	
		VITON (FPM)	
7	PLUG	MILD STEEL	
		STAINLESS 304 ASTM A276	

TEMPERATURE RESTRICTIONS		
SEAT	MIN	MAX
EPDM	-40F	300F
NBR	-30F	250F
FPM	-10F	400F
PTFE	-100F	450F

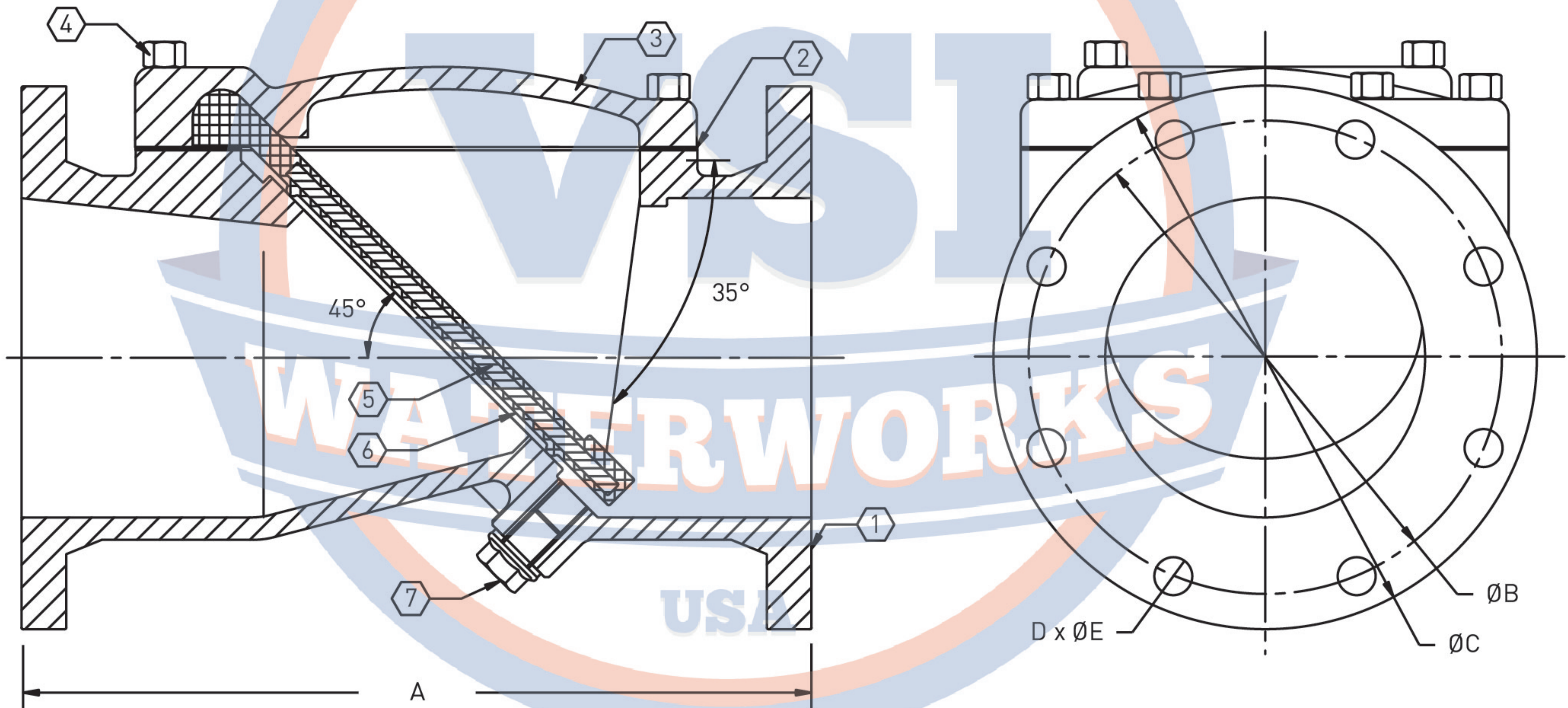

TOLERANCES	
DECIMAL	ANGULAR
X.X	±0.1
X.XX	±0.02
X.XXX	±0.008

NOTES:

- 1) FLANGES PER ASME/ANSI B16.1 CL125 AND B16.5 CL150
- 2) VALVE MANUFACTURED & TESTED IN ACCORDANCE WITH AWWA C508 LATEST REVISION

CAST EMBOSSED ON VALVE BODY:

- VSI
CASTING YEAR
250 PSI
AWWA C508
POUR IDENTIFIER

REV.	DATE	BY	DESCRIPTION
4	12-8-16	MN	DELETE PIVOT
3	05-27-15	TT	CORRECT PRESS.
2	04-24-15	TT	EDIT TRIM
1	05-13-14	TT	CORRECT 14-INCH BC

ECO-LIZER



VSI WATERWORKS
1155 ALPHA DR.
ALPHARETTA, GA

2"-24" FLANGED SERIES CVII
ECO-LIZER RUBBER FLAP
AWWA C508 CHECK VALVE

UNITS: INCHES REV 4
SCALE: NTS 12-28-2016

DWG. NO. CVII-1050