



**SERIES CVII
AWWA C508
RUBBER FLAPPER CHECK VALVES
2" - 30"**



Series CVII

Rubber Flapper Check Valves
to AWWA C508



SIMPLE ROBUST DESIGN

With only a single moving part there are no packings, o-rings, hinges, or other mechanical parts to wear out. The disc mechanism is backed by a 25 year warranty.

REINFORCED DISC

The one piece molded disc features steel and nylon reinforcement in strategically placed areas to ensure years of maintenance free operation. The disc mechanism is backed by a 25 year warranty.

NON-CLOGGING DESIGN

The Series CVII has a 100% flow area leading to excellent flow characteristics and low headloss. Large unrestricted flow area results in passage of large solids and debris minimizing potential for clogging.

THREADED PORT

The bottom mount threaded port allows field installation of accessories including backflow actuator, position indicator, and closure cushioning. Port is on the upstream side of valve, allowing removal/installation of accessories on pump headers without requiring shutdown of the entire system

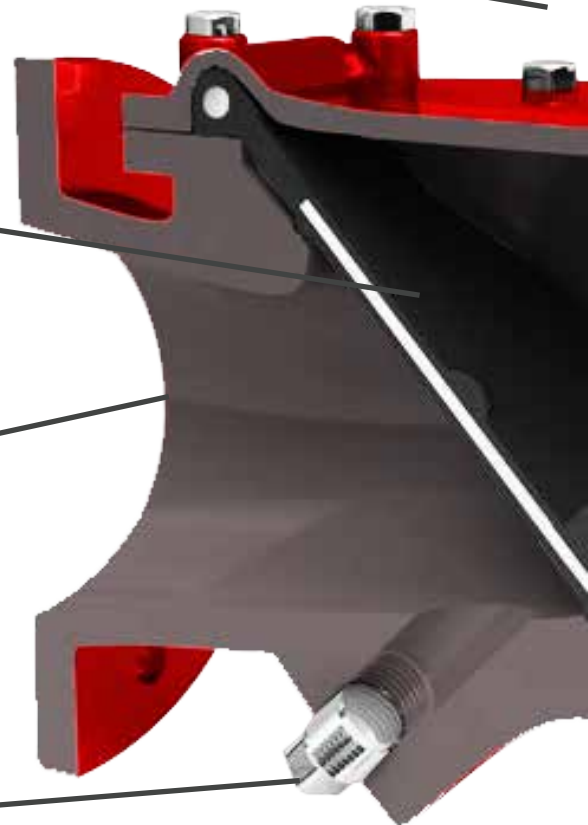

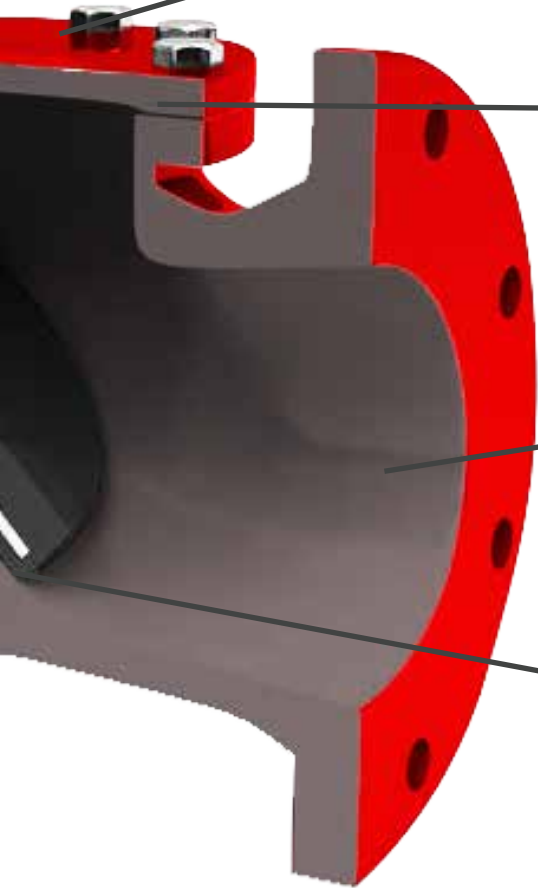

STAINLESS HARDWARE

Valves come standard with Stainless Steel 304 hardware for long service life in buried/submerged and harsh service conditions. Additional options available for corrosive and extreme exposures.

LARGE ACCESS PORT

The large top full size access port allows full service, including removal of the disc, without removing the valve from the pipe.

FUSION BONDED EPOXY

Fusion Bonded Epoxy (FBE) is provided as standard on the interior and exterior of the Series CVII Check Valves. The standard FBE is ANSI/NSF 61 listed. Specialty coatings/linings available on request.

DRIP TIGHT SEATING

The disc features a integral molded raised o-ring type seal to provide positive leak free seating at very low pressures all the way to the rated pressure.

Series CVII

Rubber Flapper Check Valves
to AWWA C508



The VSI Advantage

High Strength Ductile Iron

All Series CVII Check Valves come standard with the far superior Ductile Iron body. The higher strength of Ductile Iron compared to Cast Iron allows all valves up to 24" to be rated to a full 250 psi.



Size	AWWA C508	Series CVII
2"-12"	175psi	250psi
14"-24"	150psi	250psi
30"	150psi	150psi

Simplicity Leads to Long Life

As standard all Series CVII Check Valves feature a one-piece reinforced molded rubber disc with the flexible portion warranted for 25 years. It is available in many rubber formulations to ensure compatibility with any process. The main portion of the disc is reinforced with a steel or iron casting to ensure the high pressure rating of the Series CVII. The hinge portion is reinforced with nylon fiber to ensure long trouble free life.

The disc is molded with an integral raised o-ring type seal. The raised seal ensures drip tight sealing at low pressures down to 5 ft of head and lower.



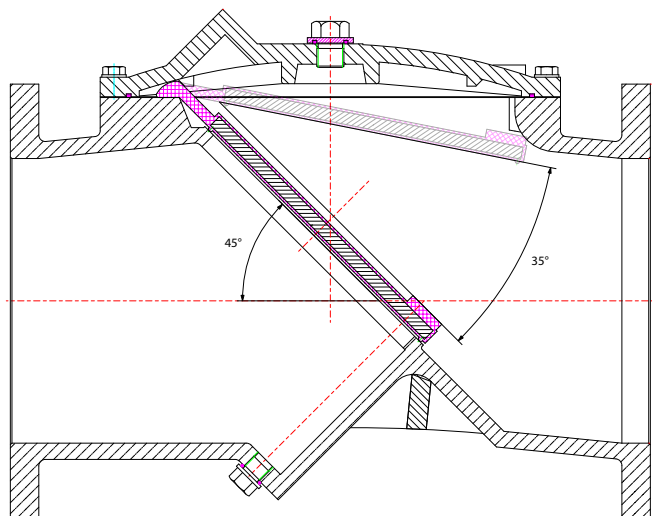

Performance

The Series CVII Check Valve is able to achieve rapid closure through a short stroke of only 35° compared to the stroke of approximately 90° for a traditional swing check valve. The resilient nature of the hinge adds an inherent spring to the operating mechanism further speeding closure while keeping pump head resistance to a minimum.

Easy to Service

With only two moving parts the Series CVII can be fully serviced in the field with simple hand tools and without removing the valve from the system. The disc/seal can be completely replaced by simply removing the large top cover. The port for backflush override, position indication, and other accessories is on the low pressure upstream side of the valve, allowing servicing of valves in pump headers without the need to shut down the entire pump header.



PAGE 5



WATER QUALITY

Underwriters Lab Inc. listed

ANSI/NSF 61

Also classified

ANSI/NSF 372

<MH60347>

Product Certifications

The VSI Series CVII Check valve is certified for use in drinking water in accordance with ANSI/NSF 61 and Certified Lead Free to ANSI/NSF 372. Every valve is designed and tested to AWWA C508. All valves are fully hydraulically tested for seat leakage and body shell pressure.



Sample Specification

Resilient Flap Check Valves for Waterworks Service

- 1.1. This specification covers the design, manufacture, and testing of cast resilient flexible check valves 2 inch (75 mm) and larger under service pressure of up to 250 psig (1724 kPa).
- 1.2. Resilient flexible check valves shall be of the full flow body type with only a single moving part.
2. GOVERNING STANDARDS
 - 2.1. All resilient flexible check valves shall be in full conformance with the design, manufacturing, and testing standards set forth by the American Water Works Association (AWWA) in Standard ANSI/AWWA C508.
 - 2.2. When requested, manufacturer shall provide an Affidavit of Proof of Design Testing in accordance with AWWA.
 - 2.3. When valves are to be used in potable water service they shall be certified to ANSI/NSF 61 for Drinking Water System Components and ANSI/NSF 372 for Low Lead Content by a national third party testing laboratory.
3. CONNECTIONS
 - 3.1. Flanged valves shall conform to all standards of ANSI B16.1, Class 125 or Class 250.
 - 3.2. Flanged valves' lay length shall conform to AWWA C508 Appendix A Full Waterway dimensions. Valves meeting Clear Waterway dimensions or otherwise not fully conforming with the Full Waterway dimensions shall not be accepted.
4. MARKINGS
 - 4.1. Each valve shall be marked with the manufacturer's name, valve size, body material, and pressure rating cast into the body of the valve. Lettering shall be a minimum of 1/2 inch tall and project 1/10 inch from body.
 - 4.2. When requested check valves, except buried or submerged valves, shall be equipped with a tag identifying body and disc material in addition to manufacturer's name, pressure rating, size, date of manufacturer, and date of testing.
5. DESIGN
 - 5.1. The valve body shall be of the full waterway type. The seating surface shall be on a 45 degree angle relative to the pipe centerline. The valve shall have a short opening stroke of 35 degree to minimize disc travel.
 - 5.2. A threaded port shall be supplied on the bottom of the valve to allow for field installation of backflow actuator, closed position indicator, and/or hydraulic cushion when required. The threaded port shall be on the upstream side of the valve seat to allow removal and installation of accessories without removing entire pump header from service.
 - 5.3. Valve shall be equipped with a full size top access port that allows removal of the disc without removing the valve body from the line. The cover shall be domed to allow self flushing over the disc for valves operating in high solids content.
 - 5.4. The disc shall be of a one piece construction molded with an integral o-ring type sealing surface on its face. It shall be reinforced with alloy steel and nylon to provide service free life. The flex portion of the disc with nylon reinforcement shall be warranted for twenty-five years.
 - 5.5. A proof of design test to 1,000,000 cycles shall have been performed in accordance with AWWA C508.
 - 5.6. Valves shall provide a bubble-tight shutoff at rated working pressure.
6. MATERIALS
 - 6.1. The valve body and cover shall be constructed of ASTM A536 Ductile Iron.
 - 6.2. The disc shall be molded EPDM or NBR as specified utilizing alloy steel and nylon reinforcement. The disc should be fully encapsulated with no voids and holiday tested before and after vulcanization.
 - 6.3. All coatings shall conform to AWWA C550, ANSI/NSF 61, be holiday free, and have a minimum total dry film thickness of 10 mils.
7. OPTIONS
 - 7.1. A screw type backflow actuator shall be supplied where specified to allow opening of the valve during no-flow conditions. The backflow actuator shall be fabricated of stainless steel, bronze, and with seals matching the disc material where required.
 - 7.2. A mechanical position indicator shall be supplied where specified to provide positive closure indication. The indicator shall not impose any opening friction or spring force restrictions on the valve disc.
 - 7.3. Where required a pre-wired limit switch shall be provided to provide closed position indication to a remote location. The switch shall be rated NEMA 4 or suitable rating for the required environment.
8. MANUFACTURER
 - 8.1. Resilient flexible check valves shall be VSI Series CVII as manufactured by Valve Solutions, Inc., Alpharetta, GA USA.
 - 8.2. All valves shall be warranted by manufacturer for a minimum of 12 months.



Design Standards

Size Range	2"-30" Flanged End
Construction	AWWA C508
Coatings	AWWA C550* NSF 61 Compliant
Connections	ANSI B16.1 Class 125/ANSI B16.5 Class 150* ANSI B16.1 Class 250/ANSI B16.5 Class 300
Lay Length	AWWA C508 Appendix A Full Waterway

*Standard Option

Available as:
Underwriters Lab Inc. listed
ANSI/NSF 61
Also classified
ANSI/NSF 372
<MH60347>



WATER QUALITY



American Water Works
Association

Resistance Guide

Designation	Common Names	Composition	Min/Max Temperature Range	General Properties	Resistant to:	Attached by:
EPDM	EPDM, EPM	Ethylene-propylene-diene Monomer	-40F/250F	Excellent ozone, chemical, and aging resistance. Poor resistance to petroleum-based fluids	Animal and vegetable oils, ozone, strong and oxidizing chemicals.	Mineral oils and solvents, aromatic hydrocarbons
NBR	NBR, Buna-N	Nitrile-butadiene	-30F/225F	Excellent resistance to petroleum-based fluids. Good physical properties	Many hydrocarbons, fats, oils, greases, hydraulic fluids, chemicals	Ozone, ketones, esters, aldehydes, chlorinated and nitro hydrocarbons
FPM	FPM, Viton®	Hexafluoropropylene-vinylidene fluoride	-10F/400F	Excellent oil and air resistances both at low and high temperatures. Very good chemical resistance	All aliphatic, aromatic, and halogenated hydrocarbons, acids, animal and vegetable oils	Ketones, low molecular weight esters and nitro containing compounds
PTFE	PTFE, Teflon®	Polytetrafluoro-ethylene	-100F/450F	Excellent abrasion resistance and chemically inert	Acids, harsh inorganic and organic chemicals, oils, oxidizing agents, and solvents	Molten alkali metals and fluorine at high temperatures



Pressure/Temperature Ratings

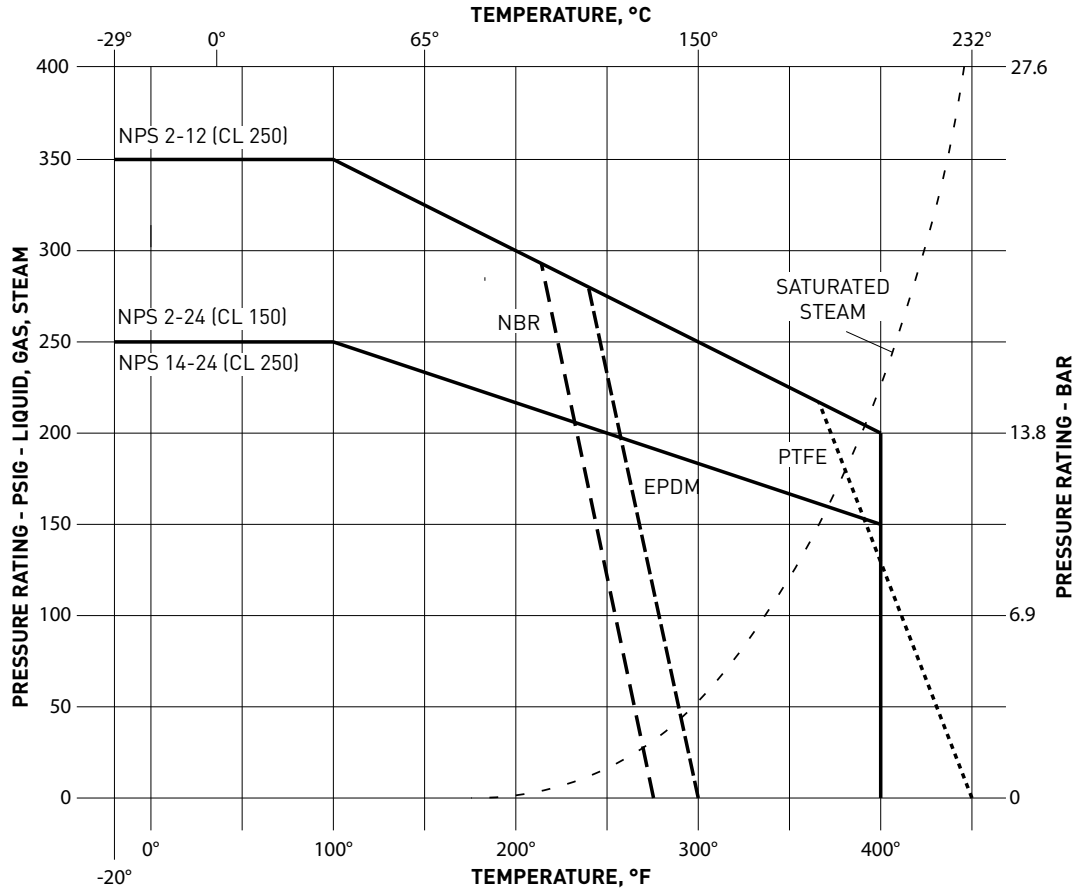

In determining field pressure ratings for Series CVII Check Valves that are constructed of Ductile Iron the above chart should be used. Pressure cast on valve represents maximum seating pressure; maximum hydrostatic pressure is temperature dependent, and may be higher than nominal pressure rating.

PAGE 8



Flow Characteristics

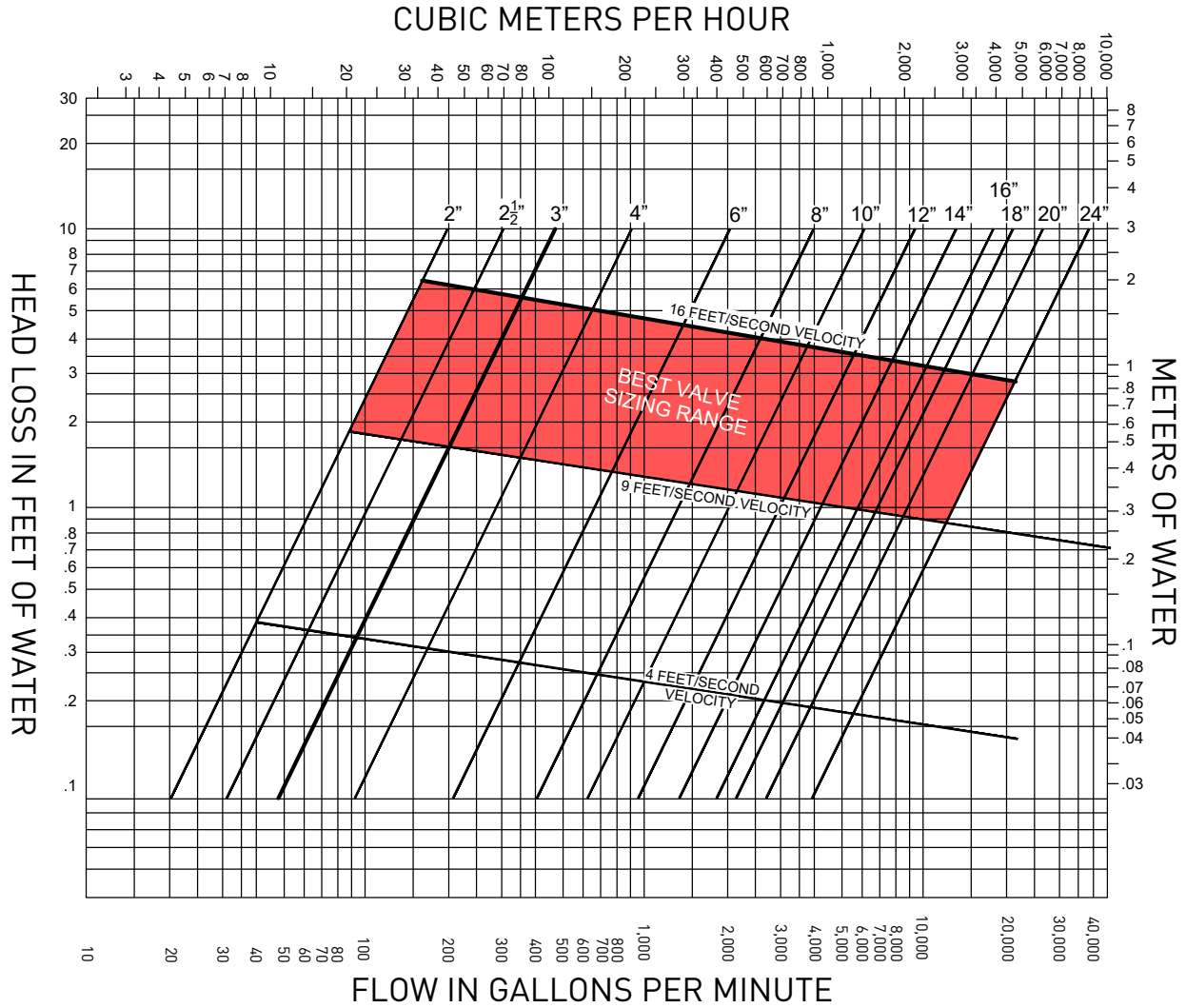

Size	2"	2.5"	3"	4"	5"	6"	8"	10"	12"	14"	16"	18"	20"	24"
Cv	100	158	229	445	713	1045	1910	3075	4650	6675	8750	11100	14250	22150



Materials of Construction

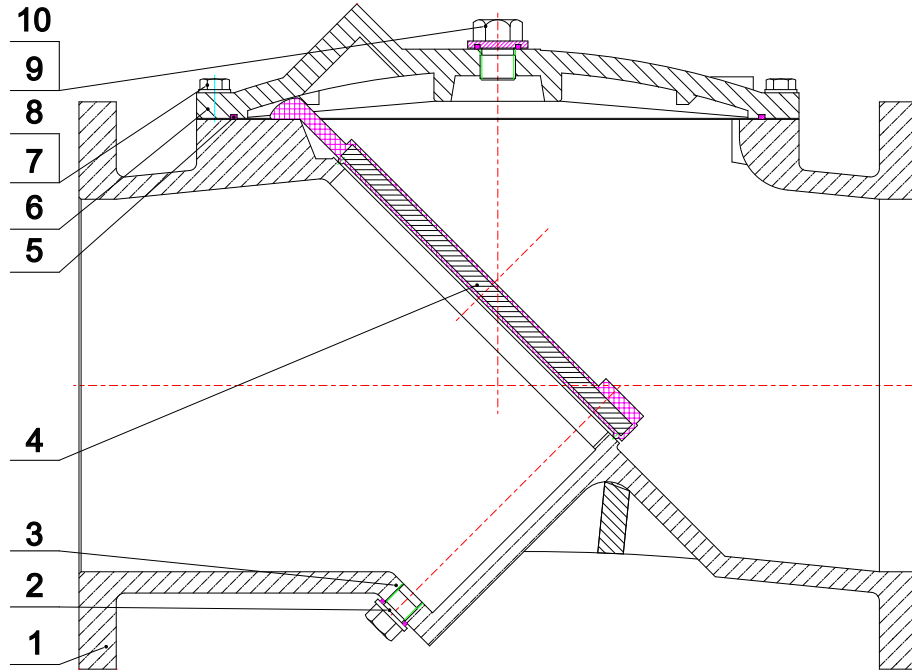

Item	Description	Materials Available	Standard
1	Body	Ductile Iron*	ASTM A536 65-45-12
		Stainless Steel 304	ASTM A351 CF8
		Stainless Steel 316	ASTM A351 CF8M
2	Plug	Stainless 304*	
		Stainless 316	
3	Seal	PTFE	
4	Disc (w/Reinforcement)	EPDM*	
		Buna-N (NBR)	
		Viton (FPM)	
5	Cover Seal	Same as Disc	
6	Cover	Same as Body	
7	Bolts	Stainless 304*	ASTM F593/594
		Stainless 316	ASTM F593/594
		Plated Steel	ASTM A325 Type 1
		Bronze	C651
8	Washers	Same as Bolts	
9	Plug ¹	Stainless 304*	
		Stainless 316	
10	Seal ¹	PTFE	

*Standard Material

1) 14" and larger only

Additional material options available as special order.



Flange with No Accessories

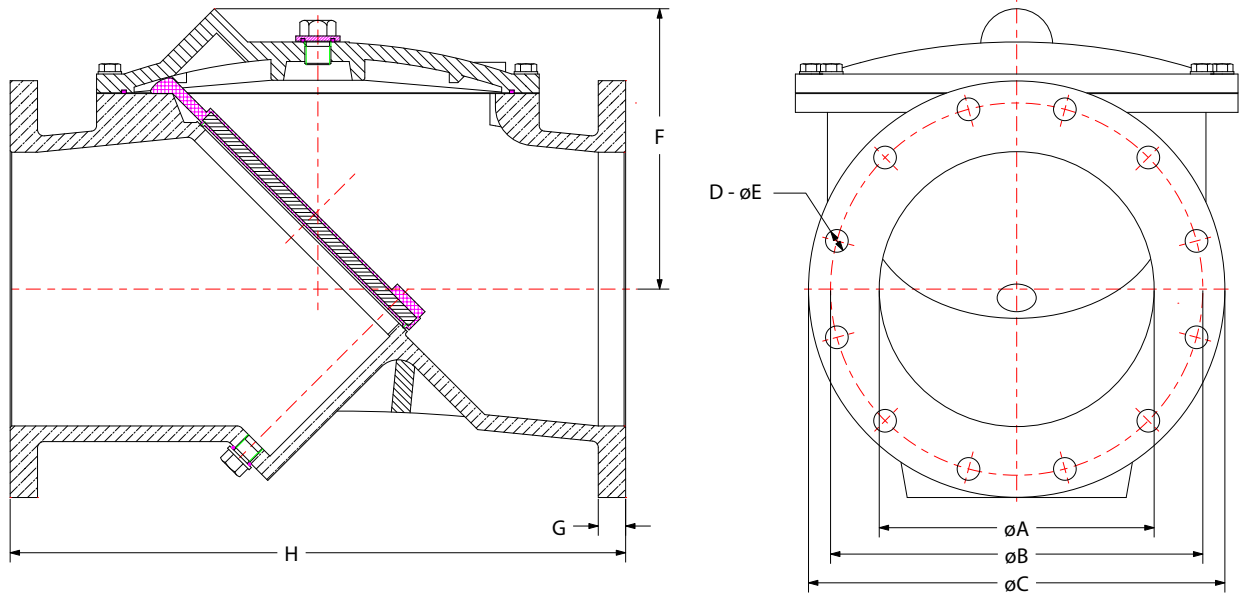

PAGE 11

SIZE	A	B	C	D	E	F	G	H	WEIGHT
2"	2	4 3/4	6	4	3/4	4 1/8	5/8	8	24
2-1/2"	2 1/2	5 1/2	7	4	3/4	4 1/2	11/16	8 1/2	29
3"	3	6	7 1/2	4	3/4	4 15/16	3/4	9 1/2	38
4"	4	7 1/2	9	8	3/4	5 5/16	15/16	11 1/2	67
5"	5	8 1/2	10	8	7/8	6 5/16	15/16	13	91
6"	6	9 1/2	11	8	7/8	7 3/8	1	14	116
8"	8	11 3/4	13 1/2	8	7/8	8 13/16	1 1/8	19 1/2	191
10"	10	14 1/4	16	12	1	10 1/16	1 3/16	24 1/2	293
12"	12	17	19	12	1	11 9/16	1 1/4	27 1/2	418
14"	14	18 3/4	21	12	1 1/8	14 1/8	1 3/8	31	678
16"	16	21 1/4	23 1/2	16	1 1/8	16 1/4	1 7/16	36	1060
18"	18	22 3/4	25	16	1 1/4	18 15/16	1 9/16	40	1374
20"	20	25	27 1/2	20	1 1/4	21 5/8	1 11/16	40	1682
24"	24	29 1/2	32	20	1 3/8	26 7/16	1 7/8	48	2778
30"	27 9/16	36	38 3/4	28	1 3/8			57	

Flange dimensions to ANSI/ASME B16.1 Class 125



Flange with Backflush Attachment

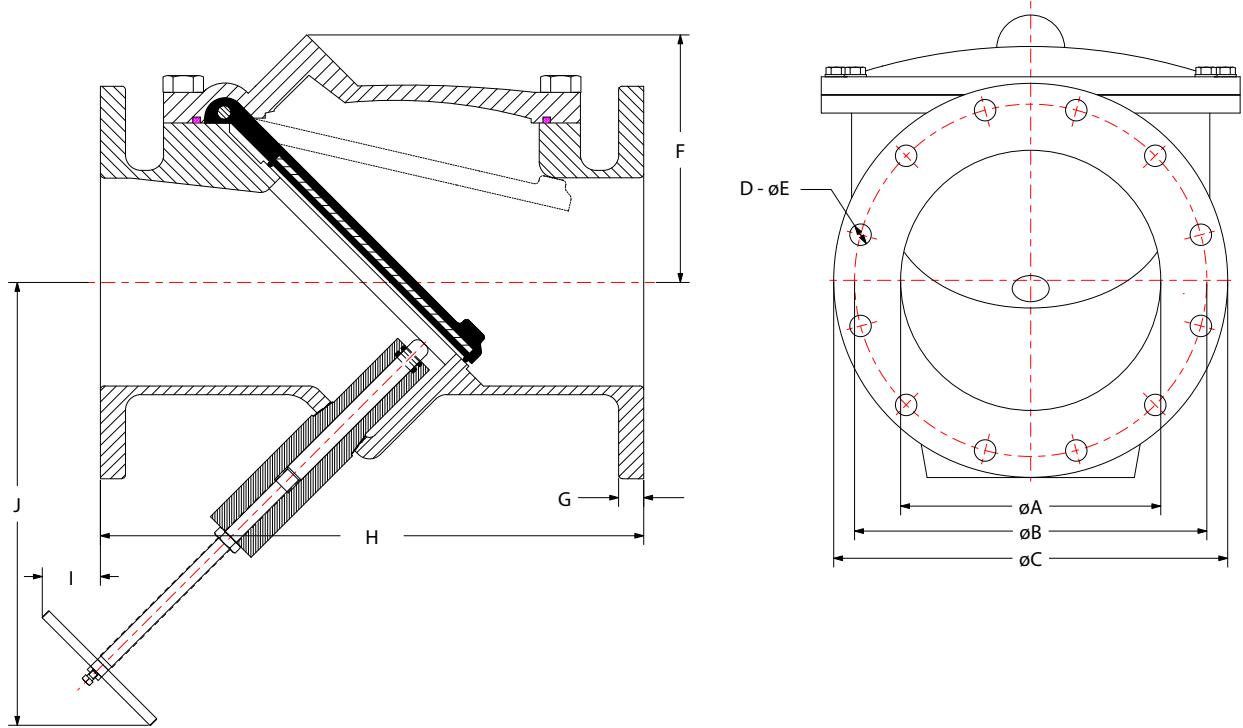

PAGE 12

SIZE	A	B	C	D	E	F	G	H	I	J	WEIGHT
2"	2	4 3/4	6	4	3/4	4 1/8	5/8	8	2 3/16	9	29
2-1/2"	2 1/2	5 1/2	7	4	3/4	4 1/2	11/16	8 1/2	1 3/4	9	34
3"	3	6	7 1/2	4	3/4	4 15/16	3/4	9 1/2	1	10	42
4"	4	7 1/2	9	8	3/4	5 5/16	15/16	11 1/2	3 1/4	10	71
5"	5	8 1/2	10	8	7/8	6 5/16	15/16	13	3 1/4	12	96
6"	6	9 1/2	11	8	7/8	7 3/8	1	14	4 1/4	15	120
8"	8	11 3/4	13 1/2	8	7/8	8 13/16	1 1/8	19 1/2	4 1/4	19	196
10"	10	14 1/4	16	12	1	10 1/16	1 3/16	24 1/2	5 1/4	22	298
12"	12	17	19	12	1	11 9/16	1 1/4	27 1/2	5 1/2	25	422
14"	14	18 3/4	21	12	1 1/8	14 1/8	1 3/8	31	5 1/2	28	682
16"	16	21 1/4	23 1/2	16	1 1/8	16 1/4	1 7/16	36	6 1/4	32	1064
18"	18	22 3/4	25	16	1 1/4	18 15/16	1 9/16	40	6 1/4	36	1378
20"	20	25	27 1/2	20	1 1/4	21 5/8	1 11/16	40	7	41	1687
24"	24	29 1/2	32	20	1 3/8	26 7/16	1 7/8	48	7	48	2782
30"	27 9/16	36	38 3/4	28	1 3/8			57			

Flange dimensions to ANSI/ASME B16.1 Class 125



PART NUMBER MATRIX

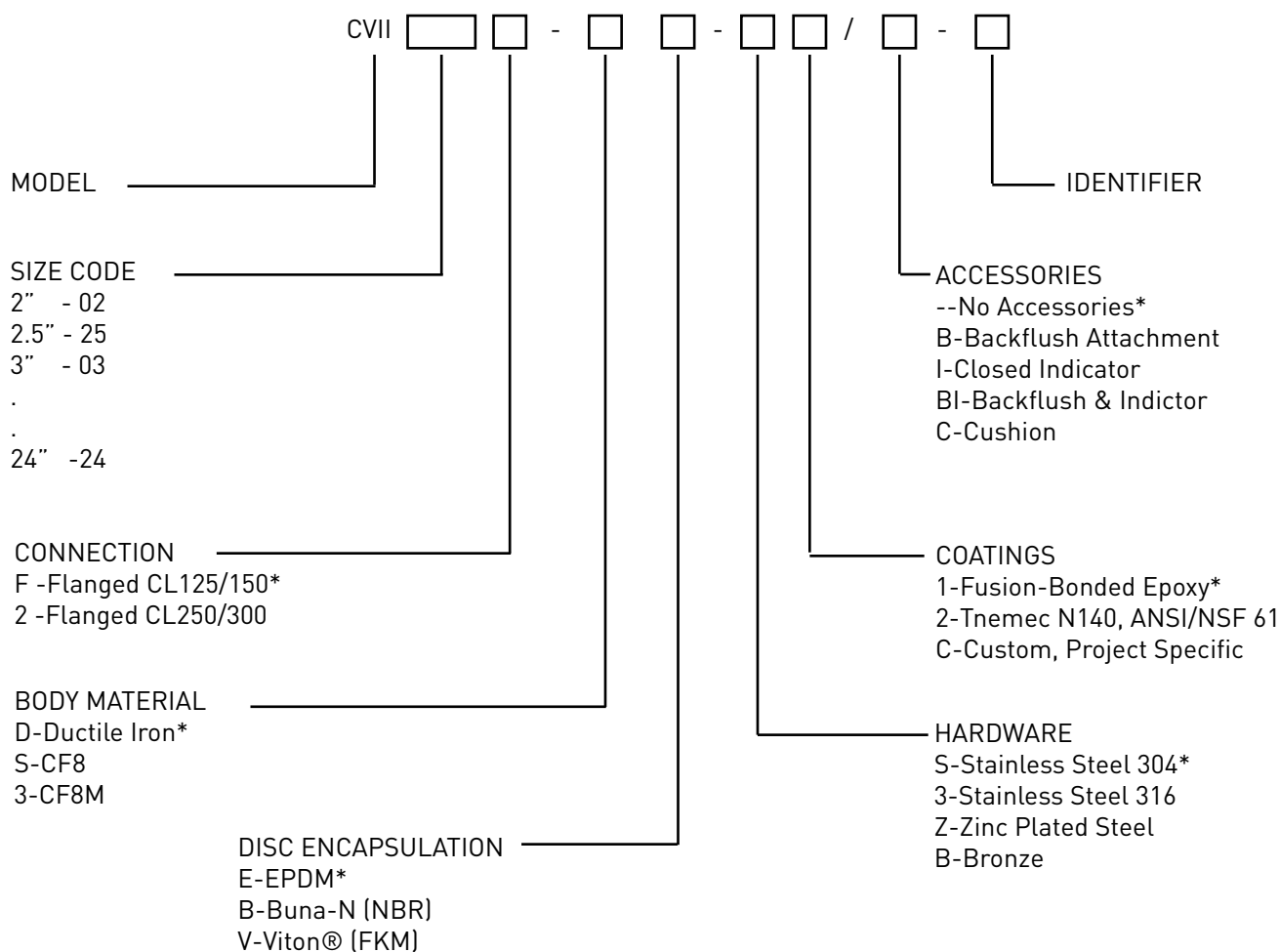

* Standard Material

EXAMPLE:

CVII06F-DE-S1/--

A 6" flanged check valve with Ductile Iron body, reinforced EPDM disc, SS304 hardware, fusion-bonded epoxy coatings with no accessories

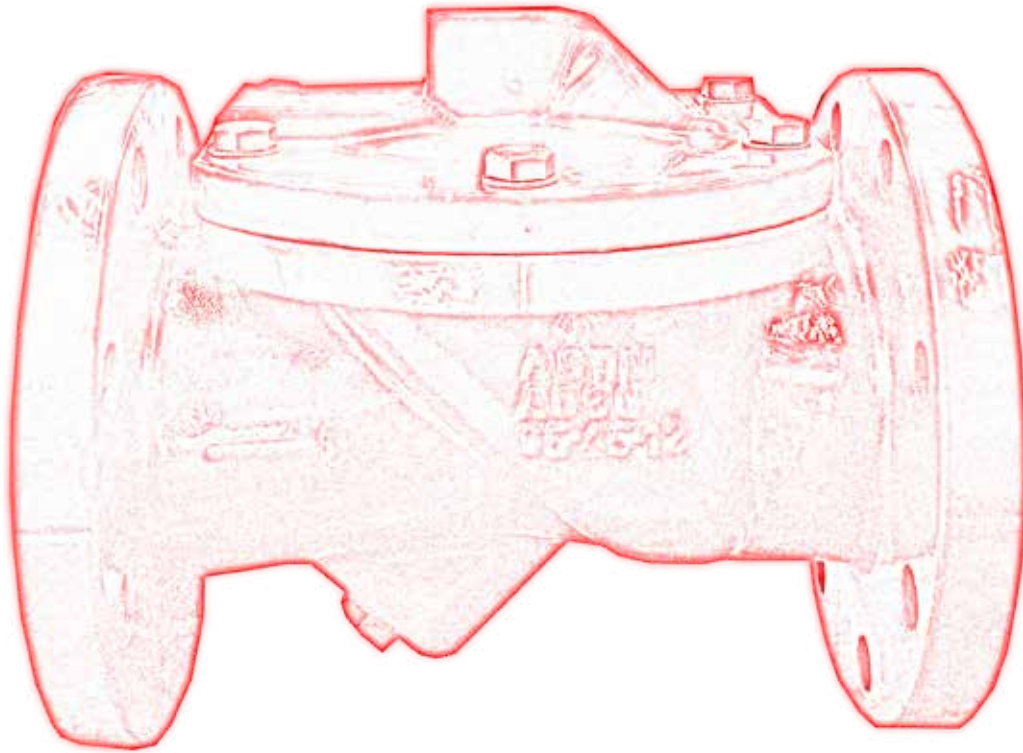

VSI Waterworks LLC

tel: 1 (770) 740 0800

fax: 1 (770) 740 8777

email: sales@vsiwaterworks.com



www.VSIWaterworks.com

As part of a process of on-going product development, VSI reserves the right to amend or change specifications without prior notice. Published data may be subject to change. For the latest version, visit our website at www.vsiwaterworks.com